

WATER CHILLER USER MANUAL

WC5



Safety Warning:



Do not leave your machine unattended.

Avoid using any water but distilled in your machine as it can damage it over time.



Always keep a fire extinguisher and first aid kit nearby.

Do not attempt to access any electrical areas while the machine is on. Unplug the machine and wait for an hour before accessing panels.

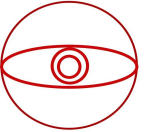

If your machines alarm is ringing, then don't start any projects until the issue has been resolved.



Inspect your machine before each use. Do not use if the machine or if the tubes are damaged in any way.

Always maintain a clean work area.

Looking for financing or eager to buy, contact Sales:



M-F 8AM-5PM PST
sales@fslaser.com
702-802-3101

Need help, visit us at our [Help Center](#) or contact Support:



M-F 8AM-5PM PST
support@fslaser.com
702-802-3103

Specifications:

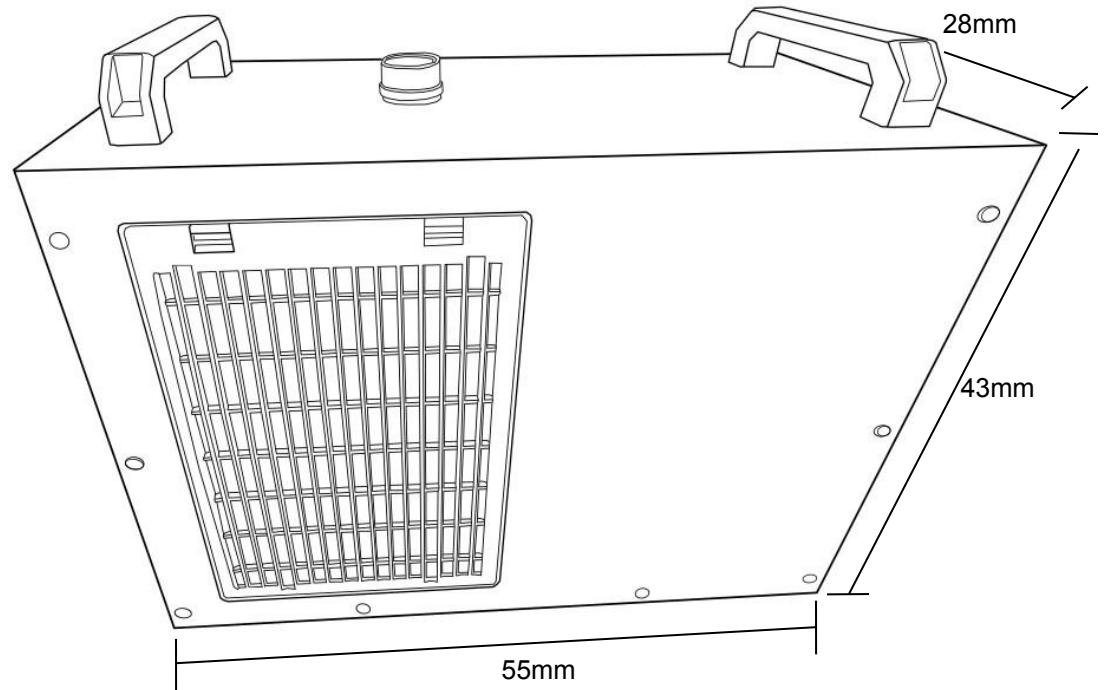

Dimension:	47mm X 37mm x 27mm
Voltage:	AC 100 - 110V
Frequency:	60 Hz
Current:	3.5 - 5.6 A
Cooling:	50W/°C
Water Capacity:	6 Liters
Max Flow:	10L/min

Diagrams:

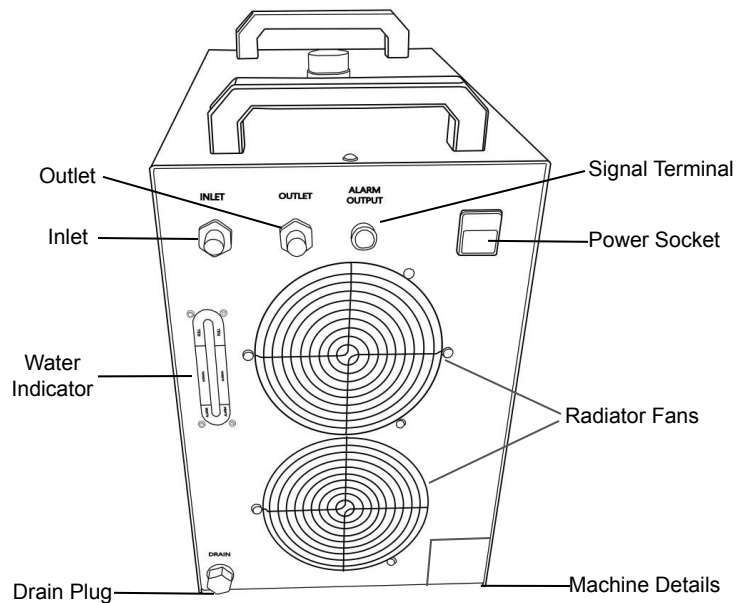
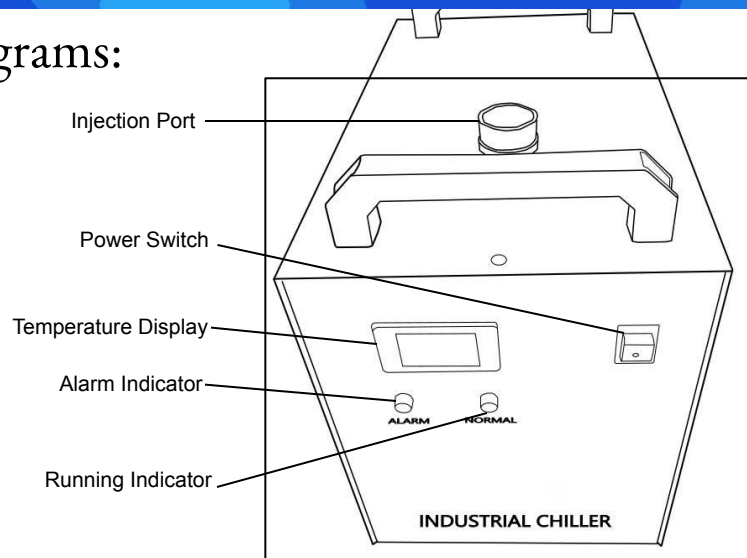

Alarm Description:

The chart below can assist in becoming acquainted with the various alert indicators of the machine and the possible problems that may occur.

Red Indicator	Green Indicator	Buzzing	Out H1 , H2	Out H1 , H3	Condition
⊘	✓	⊘	⊘	✓	Normal
✓	⊘	✓	✓	⊘	Water Stopped
✓	⊘	✓	✓	⊘	Water Shortage
✓	⊘	✓	✓	⊘	Pump Issues
✓	⊘	✓	✓	⊘	Machine temperature exceeded 60°C
			✓	⊘	Faulty circuit
			✓	⊘	Power Outage

Note: The flow alarm is connected to an open and closed relay, therefore it required the operating current to be less than 5 A and the working voltage to be less than 300V.

Temperature Display:

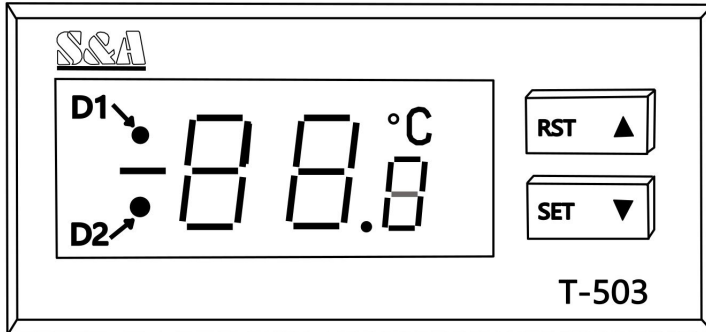

The thermostat has the following indicators: D1 and D2, shown above.

If **D1** is **ON**, then the thermostat operates in intelligent control mode. If **D1** is **OFF**, then the thermostat operates in temperature control mode. If **D1** FLASHES, then the thermostat is in parameters setting mode or displaying the value of the room temperature.

On the other hand, if **D2** is **ON**, then the chiller is in refrigerating state. If **D2** is **OFF**, then the chiller is in the insulation working state. If **D2** FLASHES, then the chiller is in the energy-saving state.

By pressing the button, the room temperature is displayed. Six seconds later, the thermostat displays the restore defaults while **D1** is flashing, indicating the room temperature. The keys are used for adjusting the display status of the controller, parameters selection, and adjustment. The **RST** key is the enter key, while the **SET** key is the function setting key.

Switching From Intelligent Mode to Manual:

1. Hold down the up and down arrows, then turn on the Chiller with the power switch.
2. The code re should appear briefly become disappearing.
3. Enter the settings mode by holding the up arrow and pressing the set button for 5 seconds.
4. The machine will beep and the display will change to zero, indication the password input. Input the default password (8) using the up arrow and selecting it with the set button.
5. Go to Function 9 (F9) and use the set button to enter the temperature display and set your minimum temperature.
6. Go to Function 0 (F0) and use the set button to enter the temperature display and set your temperature.
7. Then enter Function 2 (F2) to set your temperature different. We recommend setting the temperature different to 2 degrees or less.
8. Go to Function 3 (F3) and set the value to 0 for manual mode.

Alarm Codes:

The CW-5000 has multiple display codes designed to alert the user about potential issues. In the next section, we will provide a list of the commonly displayed codes and the corresponding potential alarm problems they signify.

F0 - Temperature Setting - Sets main temperature

F1 - Temperature Values - Set the temperature range

F2 - Cooling Hysteresis - Set the lag between the input and output (only for Intelligent Mode)

F3 - Temperature Control - Set the machine to a constant temperature

F4 - High Water Temperature Alarm - activates when the water temperature exceeds set maximum. It is recommended to replace water with cooler water.

F5 - Low Water Temperature Alarm - activates when the water temperature is below set minimum

F6 - High Room Temperature Alarm - activates when the room temperature exceeds set

F7 - Password - Set a password

F8 - Max. Temp. - Set highest water temperature

F9 - Min. Temp. - Set lowest water temperature

Error Codes:

E1 - Room temperature exceeded set range

E2 - Water temperature exceeded set maximum.

E3 - Water temperature is below set minimum.

E4 - Room Temperature Sensor has failed.

E5 - Water Temperature Sensor has failed.

Troubleshooting:

The following chart lists some of the common issues experience with water chillers.

Issue	Cause	Potential Solution
Machine turns on but is not electrified	The machine is not getting proper electricity.	Check to make sure the power cord is plugged in property. If that is the working then the fuse must be burnt out and needs to be replaced.
Water Tubes are properly connected but the red light is on and there's no water flow	There is not enough water inside the system.	Check water level. If the water is full, then check for leakage.
The water is flowing but the red light is on	There is not enough water inside the system.	Check the water tubes for leakage.
High water temperature	The water chiller has reached a high temperature either by poor ventilation or due to excessive heat.	Replace the water will room temperature water. Make sure the chiller is placed in a well ventilated area to draw in air.
High room temperature	The room temperature is high enough to raise the machines temperature to above 40°C.	Work to improve ventilation so that the machine is below 40°C.
Alarm is still on after adding/replacing water	There is a possibility that water is inside the machine.	Check the water tubes for leakage. Make sure the injection cap and its surroundings are dry before covering the port.
Water is draining slow	There is no air to help with draining	Open the Injection port to let in air.

For help setting your machine to constant mode, select the following link [here](#). For other issues, go to the [Help Desk](#).