

Rotary Assembly Instructions

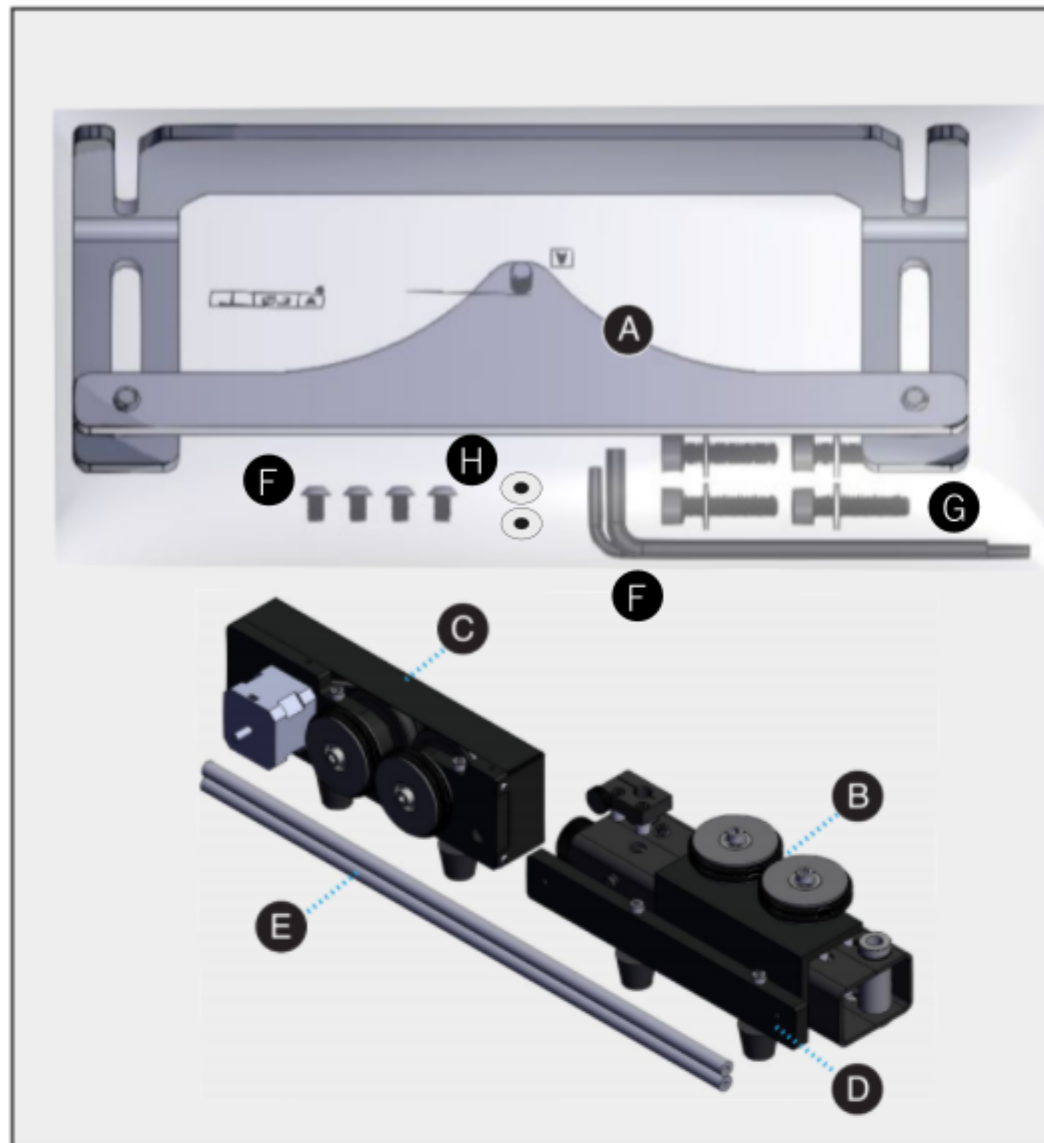

Step 1

Remove contents from box:

- Ⓐ Pressure plate Ⓑ Jack / Idler Plate
- Ⓒ Motor Plate Ⓓ Back Plate
- Ⓔ 2 Rods, and Hardware.
- Ⓕ Button Head Bolts
- Ⓖ M4 Screws
- Ⓗ Washers



Step 3

- 4) **Attach Rods:** Using the provided M4 screws and 3mm hex tool attach the ends of the Rods to the Motor Plate and Back Plate. Replace Motor Plate cover.

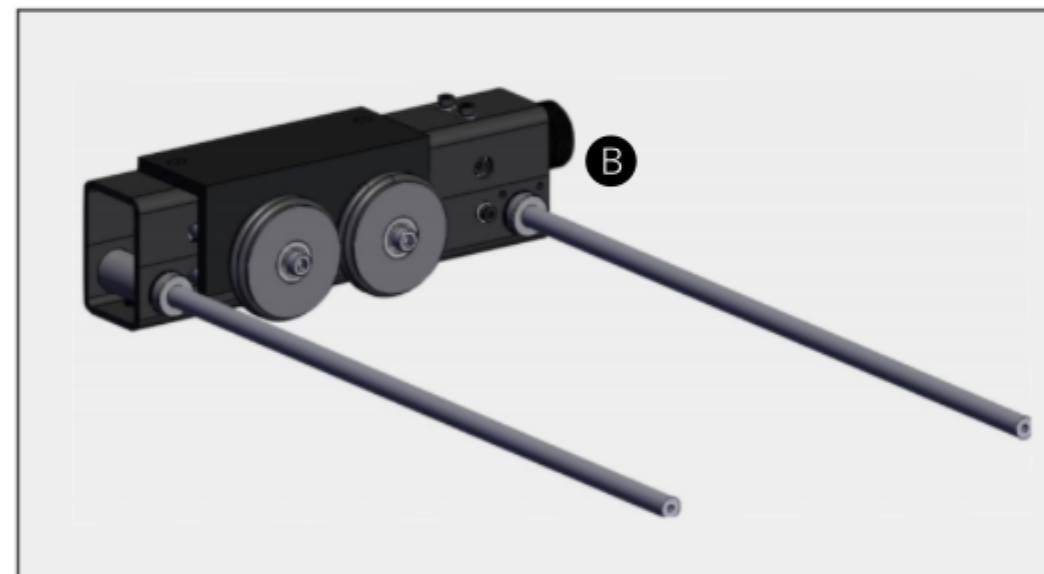

Step 2

Pre-Assemble Rotary Jack

Insert the two Rods into the Rotary Jack Linear Bearings.

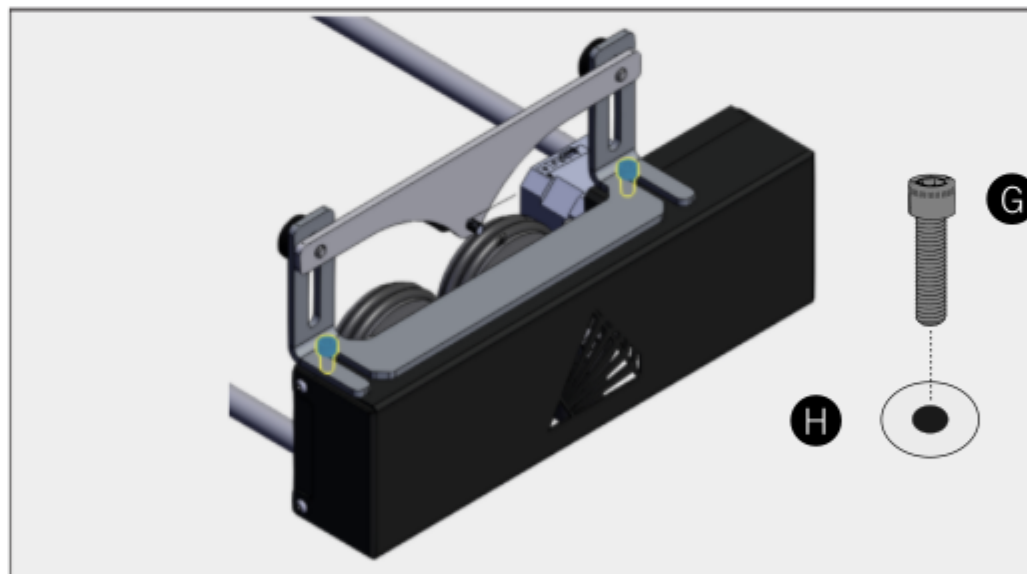

Step 4

5) Attach Pressure Plate:

Using the provided M4 screws and 3mm hex tool, attach the Pressure Plate to the top of the Motor Plate.

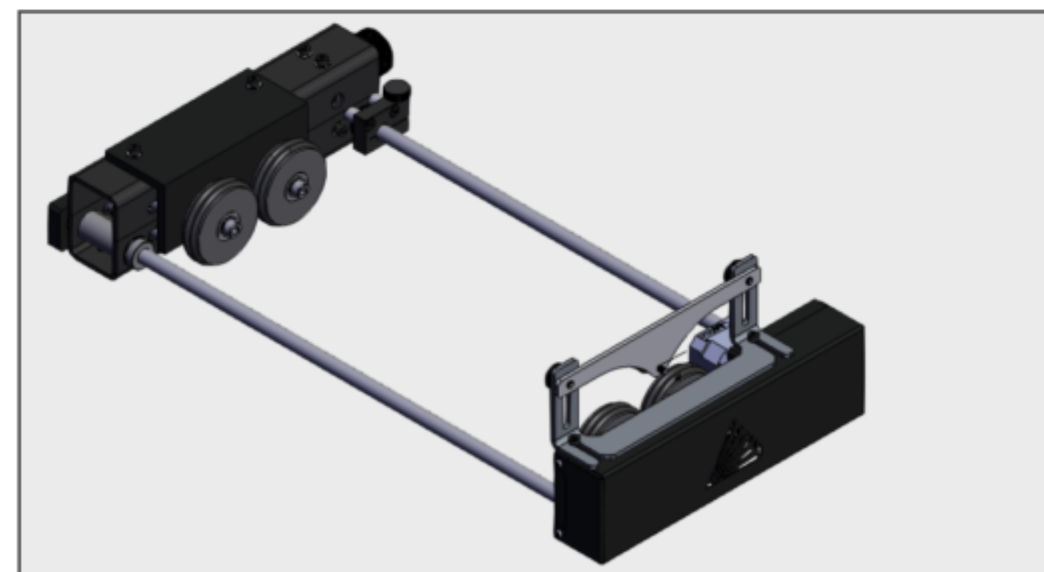

All Done!

Time to engrave on all sorts of Mugs, Cups, Tumblers, and just about any cylindrical object.

Learn More

For more advanced assembly instructions & to learn some tips & tricks check out our videos on Youtube.

YouTube
Learn more on our channel: