

Full Spectrum

L A S E R

User Guide for A series Laser Welder



CONTENT

CONTENT	1
Chapter 1 Safety Information	3
1.1 Safety Sign	3
1.2 Laser Safety Classification	3
1.3 Labels on the Product	3
1.4 Safety Instructions for Optical Operation	5
1.5 Safety Instructions for Electrical Operation	6
1.6 Other safety precautions	6
Chapter 2 Product Description	7
2.1 Property Introductions	7
2.2 Operation Conditions	7
2.3 Product Parameters	8
2.4 Overall dimensions	9
Chapter 3 Unboxing and function introduction	12
3.1 Unboxing and Inspection	12
3.2 function introduction	13
Chapter 4 Preparation before use	17
4.1 Precautions	17
4.2 Wire connection	17
4.3 GAS connection	19
4.4 Installation of clamp	20
4.5 Installation of welding wire	20
Chapter 5 Use of laser welder	22
5.1 Power on check	22
5.2 Use of the Laser welder	23
5.3 The setting of fish-scale welding	24
5.4 Fault Shielding	24
5.5 Fault Query	24
5.6 Signal Dect	25
5.7 Decryption	25
Chapter 6 Process selection	26
6.1 Focus	26
6.2 Shielding gas selection	27
6.3 Welding wire selection	27



6.4 Selection of wire feed roller	27
6.5 Use of copper nozzle	28
6.6 Process parameter reference	28
Chapter 7 Cleaning and Replacing of lens	31
7.1 Cleaning and replacing window mirrors	31
7.2 Cleaning and replacement of focusing lens	32
7.3 Cleaning of air ducts	33
Chapter 8 Common faults treatment	35
8.1 Fault alarm and query	35
8.2 Troubleshooting solution	35
Chapter 9 Warranty and Return	37
9.1 General warranty	37
9.2 Limit of warranty	37
9.3 Transportation	37

Chapter 1 Safety Information

Thank you for choosing the A series Laser Welder from Reci laser.

In order to ensure operation safety (personnel safety, equipment safety, production safety.) and product operation in the best state. We compile this document with important safety, operating, maintaining and other information. Please take time to read and understand this User's Guide and familiarize yourself with the operating and maintenance instructions before using the product.

1.1 Safety Sign

	<p>WARNING : Refers to a potential hazard that may leads to a personal injury or death.</p>
	<p>CAUTION : Refers to a potential hazard on product, or a potential physical injury on personnel.</p>

1.2 Laser Safety Classification

This laser welder uses a single-mode fiber laser, which can emit laser radiation with a wavelength in the range of $1080 \pm 3\text{nm}$, which is invisible light. This laser welder belongs to Class 4 laser equipment. Direct or indirect exposure to such light intensity can cause permanent damage to the eyes (retina and cornea) or skin. In view of this, appropriate and approved laser safety protective glasses must be worn all the time while the laser is operating. At the same time, no directly or reflectively emit on your skin.

	<p>WARNING : The laser safety protective glasses are selected according to the wavelengths of the output laser. The users must ensure that the laser safety protective glasses covered the entire range of wavelengths of the laser emission. Attention; Glasses only protect against scattered light that is greatly attenuated, Direct laser exposure can still cause irreversible damage.</p>
---	---

1.3 Labels on the Product

The specific location layout of the safety signs of each model of product is similar, mainly located on the top and rear panel of the Laser welder, and on the welding gun.

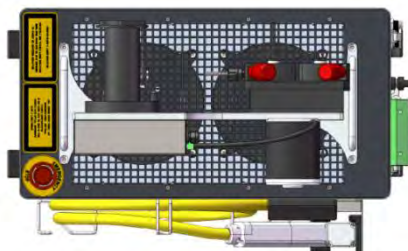

(1) Top view

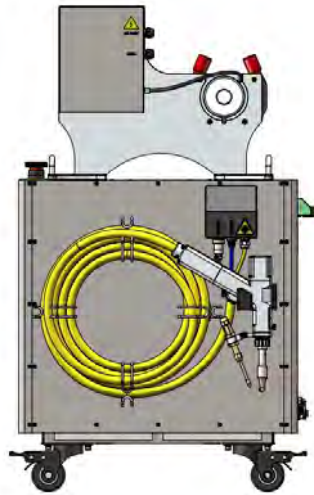

(2) Side view



(3) Rear view

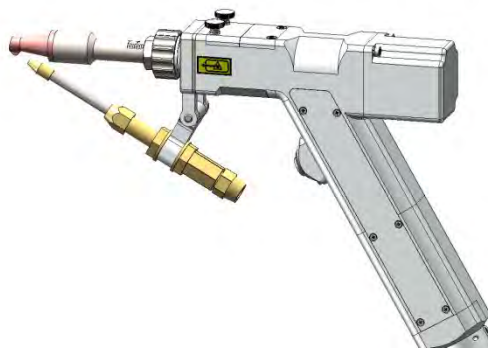



(4) Welding gun

Figure 1.1 Product safety signs and their locations

These safety signs mainly include: laser product category warning, laser radiation hazard warning, strong current hazard warning, product nameplate, etc. The details of identification are shown in the table below:

Table 1.1 Product safety label details

<p>MAX.AVERAGE OUTPUT POWER: 1mW WAVELENGTH RANGE: 600-700nm VISIBLE LASER RADIATION DO NOT STARE INTO THE BEAM OR VIEW DIRECTLY WITH OPTICAL INSTRUMENTS CLASS 2 LASER PRODUCT IEC/EN 60825-1:2014</p>	<p>WAVELENGTH RANGE: 900-1200nm INVISIBLE LASER RADIATION AVOID EYE OR SKIN EXPOSURE TO DIRECT OR SCATTERED RADIATION CLASS 4 LASER PRODUCT IEC/EN 60825-1:2014</p>
<p>(1) Class 2 Laser Product</p>	<p>(2) Class 4 Laser Product</p>
	
<p>(3) Laser Radiation Hazard Label</p>	<p>(4) Electrical Hazard</p>

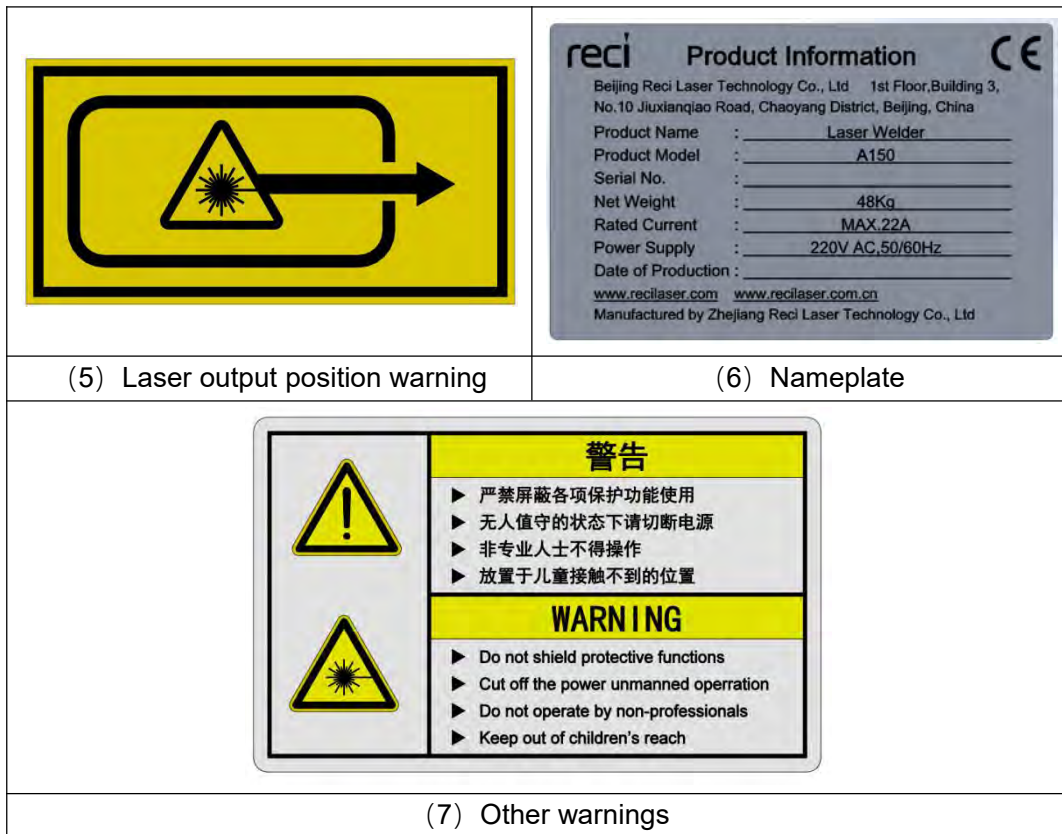

1.4 Safety Instructions for Optical Operation

- (1) Never look directly into the optical output when the Electrical switch is on.
- (2) Make sure that a pair of appropriate and approved laser safety protective glasses is worn all the time while the laser is operating.
- (3) No eyes are on the path of the laser beam (direct or reflected light, scatter light from high reflective material, etc.), at the same time, the direction of laser output must be Shelter by reliable objects.

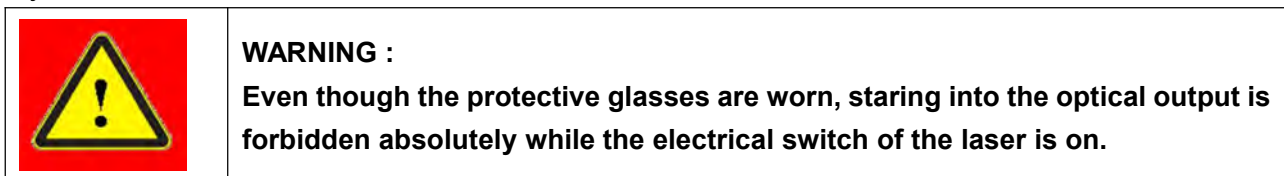

- (4) If you are ready to emit light, be sure to confirm whether the red light position is correct. The laser cannot be obtained under the following conditions:

- A: No red light.
- B: When no swing is set, the red light is not in the center.
- C: After setting the swing, the red light is blocked.

- (5) Please ensure that the protective lens of the welding gun is clean and free of dust, otherwise the laser will be irreparably damaged. Before use, carefully observe whether the protective window mirror of the welding gun is clean. If there is any pollution, the window mirror needs to be replaced. The damage caused by non-standard operation will not be guaranteed.

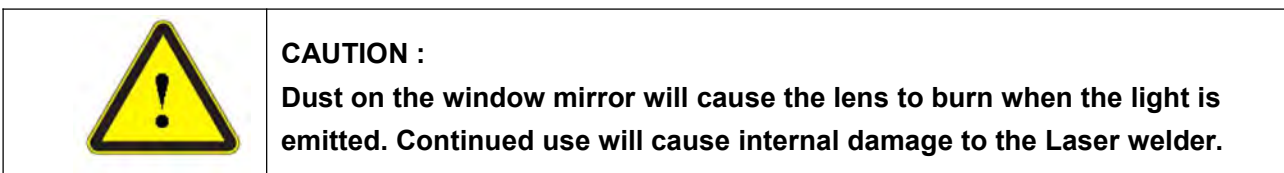

(6) If the welding gun is heated during use, please stop using it immediately and check the problem.

(7) The welding gun cannot be pointed at people.

1.5 Safety Instructions for Electrical Operation

(1) Make sure the power source connected to the equipment is properly grounded with PE wire. At the same time the shell of this equipment must be properly grounded. Any interruption of the ground loop may result in personal injury.



WARNING :

(1) The input voltage of the fiber laser is AC current (220VAC), which may cause risk of electric shock.

(2) All the relevant cables and connection wires have potential hazards.

(2) Make sure that the input AC voltage and capacity meet the requirements of the very series of lasers.

(3) If the air switch shut down frequently, please contact Reci as soon as possible to ensure the safety use of the equipment.

(4) Please cut off the power supply when unattended.



CAUTION :

(1) Any incorrect wiring method or AC voltage may cause damage to people or instrument.

(2) There are no devices in the product that need to be used by the operator. Do not try to open the product cover, otherwise electric shock may be caused, and the laser warranty will be invalid accordingly.

(3) Do not plug or unplug the wire with electricity, it is easy to cause damage to the equipment

1.6 Other safety precautions

(1) Please operate the Laser Welder in strict accordance with the product manual, otherwise any damage to the laser will not be guaranteed.

(2) Do not use the Laser Welder in a dark or dark environments.

(3) It is strictly prohibited to shield the protection. The workpiece clamp and welding gun nozzle must be closed before outputting the laser, otherwise there will be potential safety hazards.

(4) Do not operate by non professionals. Keep out of the reach of children.

(5) To prevent electric shock, please do not damage the label and remove the cover, otherwise any damage to the laser will not be guaranteed.

Chapter 2 Product Description

2.1 Property Introductions

The laser used in this product is a fiber laser. Compared with traditional gas and solid lasers, it has high electro-optical conversion efficiency and superior beam quality. Due to the low cost of optical fiber, the cost of fiber laser is also relatively low. Due to the coilability of optical fiber, optical fiber The structure of the laser is compact; in addition, the connection between devices is carried out by fiber fusion. The system is stable and reliable, adaptable to various complex environments, and can be maintenance-free. Another advantage of fiber export is that fiber lasers can easily handle various multi-dimensional arbitrary spaces. Processing applications reduce the difficulty of mechanical design.

Main Features:

- High wall-plug efficiency
- High power with Excellent beam quality
- High reliability, long service life, maintenance free
- All fiber structure, compact, rugged package
- Multiple anti-high-reflection

Applications:

- Industrial applications: Material cutting (major in metal processing) , metal welding, metal cladding
- Scientific research, Military application

2.2 Operation Conditions

The basic operating environment of this product is as follows:

Table 2.1 Operating environment of the laser welder

Model	A80, A120, A150, A200
Supply Voltage(V)	220±10% V AC 50/60Hz
Placement	Flat, upright, no vibration and impact
Environment Temperature	-5~40℃
Relative Humidity	< 90%RH
Electromagnetic Environment	Avoid too strong electromagnetic interference,which may lead to false alarm of laser
Heat dissipation mode	The laser welder adopts air-cooling heat dissipation method. Please operate the equipment in a place with good air circulation, and ensure that the distance between the left and right sides of the equipment and the wall is > 10cm, and the air pressure of the air pipe is not greater than 0.7MPa.



CAUTION :

(1) Although this product has high adaptability to high-humidity environments, it is still recommended not to operate this product in high-humidity environments (> 80%) for a long time.

(2) Excessive ambient temperature and ambient humidity will shorten the life of the Laser welder and reduce the output power.

This laser welder adopts air-cooling heat dissipation. When placing it, please operate it in a non-enclosed and small space with good air circulation conditions. Do not place any objects around and on top of the machine that may block the exhaust. The air flow direction is as follows As shown in Figure 2.2.1, the space requirements for Laser Welder placement are shown in Figure 2.2.2.



Figure 2.2.1 Air intake and exhaust diagram

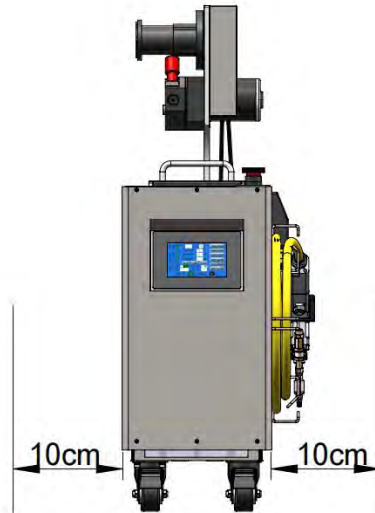

Figure 2.2.2 Placement space requirements

2.3 Product Parameters

Table 2.2 Parameters

MODEL		A80	A120	A150	A200
Optical Specification	Rated Power	700W	1000W	1300W	1850W
	Operating Mode	CW/Spot Welding			
	Polarization	Random			
	Power Range	10~100%			
	Central Wavelength	1080±3nm			
	Continuous operating power attenuation	<2%			
	Max. Modulation Frequency	5KHz			
	Red Laser power	≥0.2mW			
	Output Fiber Diameter	20µm			
	Delivery Fiber Length	Standard 5m			

MODEL		A80	A120	A150	A200
Electric Specification	Operating Voltage	AC 220V 50/60Hz			
	Power Consumption	< 3000W	<3600W	<4800W	<7000W
	Control Mode	Touch screen			
Other Specification	Dimensions W×H×D (mm3)	273×614.9×396.3	273×634.9×527.7	273×634.1×527.7	323×684.2×629
	Weight (Wire feeder included)	38kg	46kg	48kg	58kg
	Ambient Temperature	-5~40℃			
	Ambient Humidity	<90%			
	Cooling Method	Air cooling			
	Storage temperature	-10~60℃			
	Input gas pressure	≤0.7MPa			

* There are some differences between actual power and rated power, whichever is actual.

*The size and weight of each version are different. If you need accurate values, please contact our salesman.

2.4 Overall dimensions

(1) A80



Figure 2.4.1 Overall dimensions of A80

(2) A120/A150

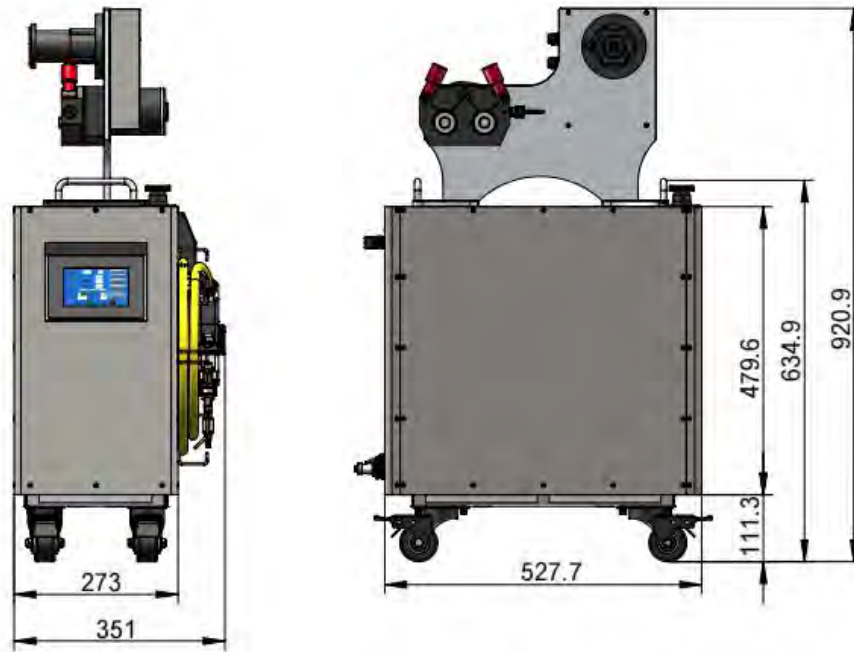

Figure 2.4.2 Overall dimensions of A120/A150

(3) A200

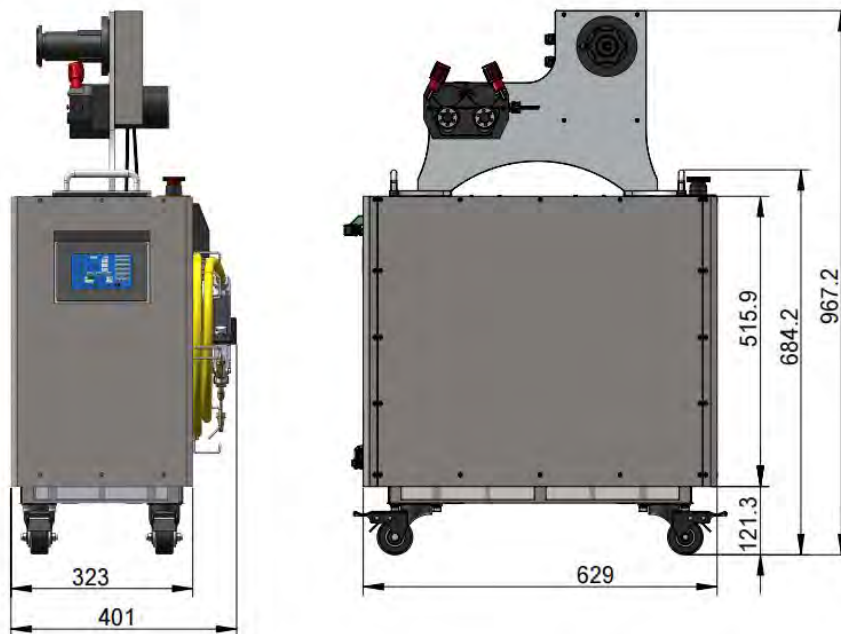

Figure 2.4.3 Overall dimensions of A200

(4) Welding gun

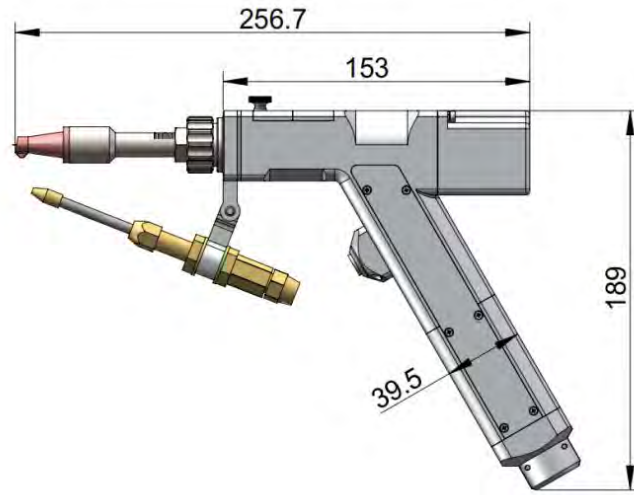

Figure 2.4.4 Overall dimensions of the Welding gun

Chapter 3 Unboxing and function introduction

3.1 Unboxing and Inspection

The packaging boxes are specially designed to ensure that the product is protected from damage during transportation. However, in order to prevent unpredictable situations during transportation, users still need to carefully check the packaging box before opening the box.

The packaging box is placed correctly, and there is no collision, cracking, rain or water immersion on the outside of the box.

Determine whether the actual items are consistent with the shipping list.

If there is no abnormality outside the box, open the box. If there is any abnormality, please do not open the box and contact Reci in time.

The unpacking steps are shown below (Figure 3.1):

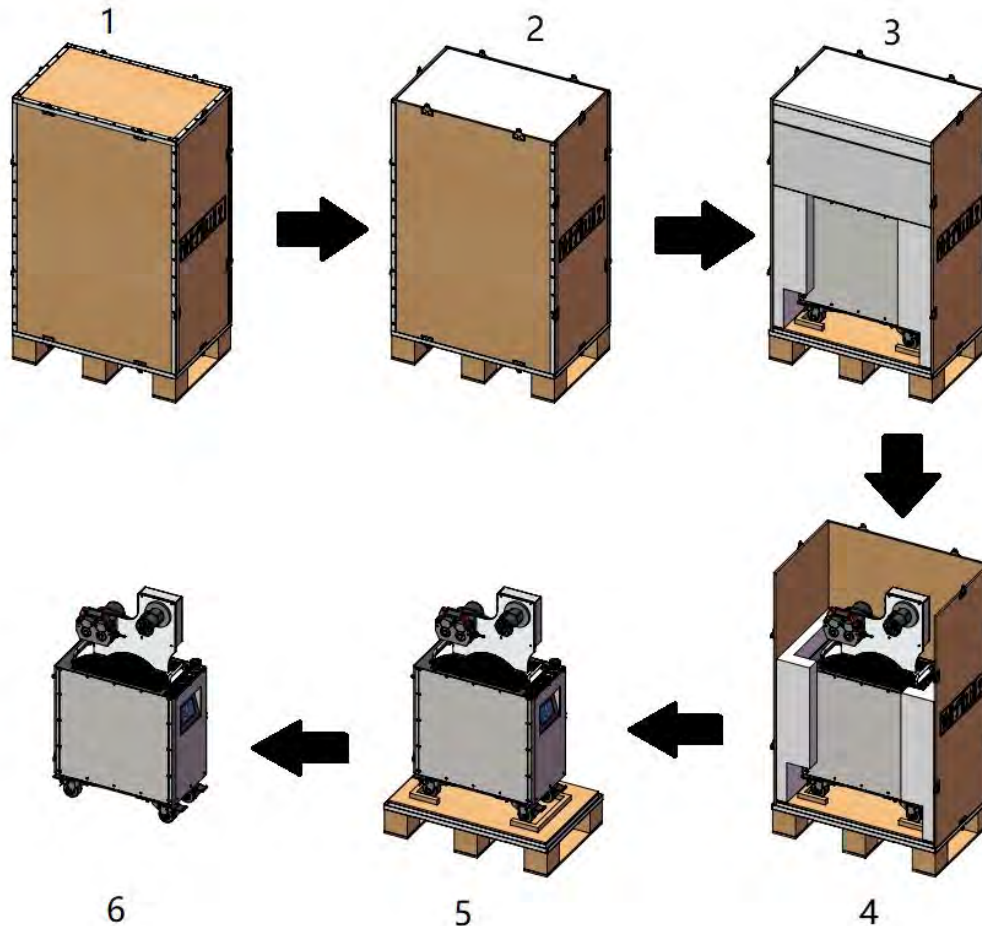

Figure 3.1

Be careful when taking out the welder from the box to avoid collision or severe vibration to the equipment. When taking out the protective tube, be careful not to get tangled, twisted, folded or pulled, and the welding gun must not be bumped or beaten.



CAUTION :

The output optical cable and welding gun are precision optical devices - twisting, excessive bending of the optical cable, strong vibration and impact on the laser output head will cause irreparable damage to the Laser Welder.

After taking out the Laser Welder, do the following inspections:

- (1) Check whether the appearance of the machine is seriously damaged. If it affects the use, please contact our after-sales personnel in time;
- (2) Check whether the included accessories are consistent with the packing list. If there is any defect, please contact our after-sales personnel in time.

3.2 function introduction

3.2.1 Front panel



Figure 3.2

Table 3.1 Front panel button function description

NO	ITEMS	FUNCTION DESCRIPTION
1	Touch screen	Set the parameters, save the parameters and select the parameters. Query and set the fault shielding. Query the fault and view detailed fault. Clear the fatal fault. Set auxiliary parameters. Detect the signal and decryption setting.
2	Emergency Stop	Temporarily suspends power to the laser. When pressed, the power supply will be disabled. Once pressed, the E-Stop can be reset by turning the red knob clockwise. Important tip: This button should be used in the emergency, and there is no need to press it for the normal shutdown.

3.2.2 Rear Panel



Figure 3.3

Table 3.2 Functions of the specific interface on the rear Panel

No.	ITEMS	FUNCTION DESCRIPTION
1	CTRL-INTERFACE	12-pin interface connection, and see section 3.3 for details.
2	CLAMP	Workpiece clamp cable attaches to this CLAMP. This closes the safety interlock loop between the welder nozzle tip and this CLAMP. It ensures the weld head is connected to the work piece before emission can safely be turned on.
3	GAS IN	Connect tubing with the outer diameter of 6mm and inner diameter of 4mm from gas supply tank to rear panel input port.
4	220V AC OUTPUT	AC output socket:220V AC, 50/60Hz, I _{max} 5A.
5	Air Switch	Power switch of AC power. Push on, open the AC power. Push down, close the AC power.
6	220V AC INPUT	AC input socket:220V AC, 50/60Hz.

The CTRL-INTERFACE adopts 12-pin welding-free terminal blocks with flanges with the pitch of 5.08mm, which is convenient and reliable to connect. The terminal pins are 1~12 from left to right, as shown in Figure 3.4.

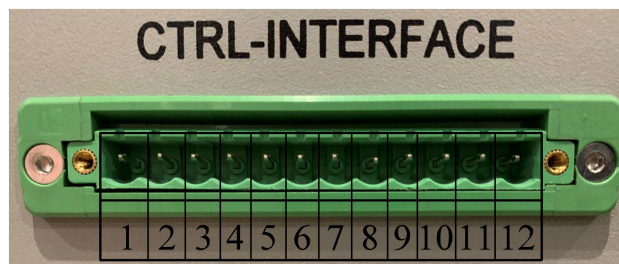

Figure3.4 CTRL-INTERFACE

Table 3.3 12-pin definition of the CTRL-INTERFACE

PIN	DESCRIPTION	REMARK
1	RS485A	RS485 for the parameter setting or used for the wire feeder
2	RS485B	
3	INTERLOCK+	External Safety Interlock. Laser cannot be started without the required safety interlocks being in place and satisfied. Warning:No active signal should be accessed
4	INTERLOCK-	
5	ALARM_OUT+	Alarm signal normally open output, used for external indicator lights, etc. Closed if the output is active. $I_{max} \leq 0.5A @ 24V$ DC.
6	ALARM_OUT-	
7	EMISSION_OUT+	Emission signal normally open output, used for the wire feeder, etc. Closed if the output is active. $I_{max} \leq 0.5A @ 24V$ DC.
8	EMISSION_OUT-	
9	RESERVED	RESERVED
10	RESERVED	RESERVED
11	RESERVED	RESERVED
12	RESERVED	RESERVED

3.2.3 Side panel

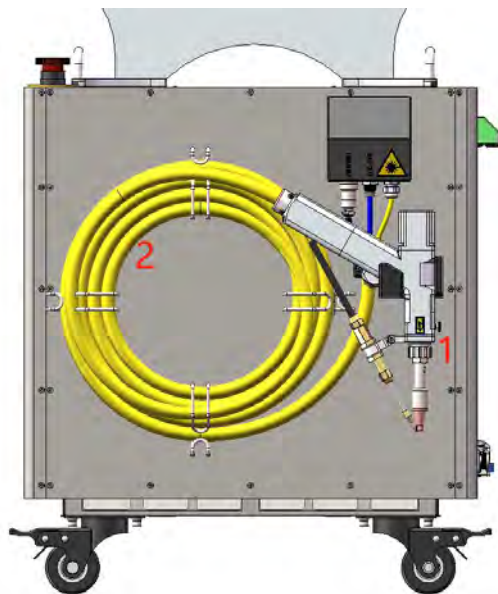

Figure 3.5

Table 3.4 Side part introduction

No.	Name	DESCRIPTION
1	welding gun	Laser output head
2	Protective tube	Contains air tubes, wire bundles, optical fibers, etc.

3.2.4 Above

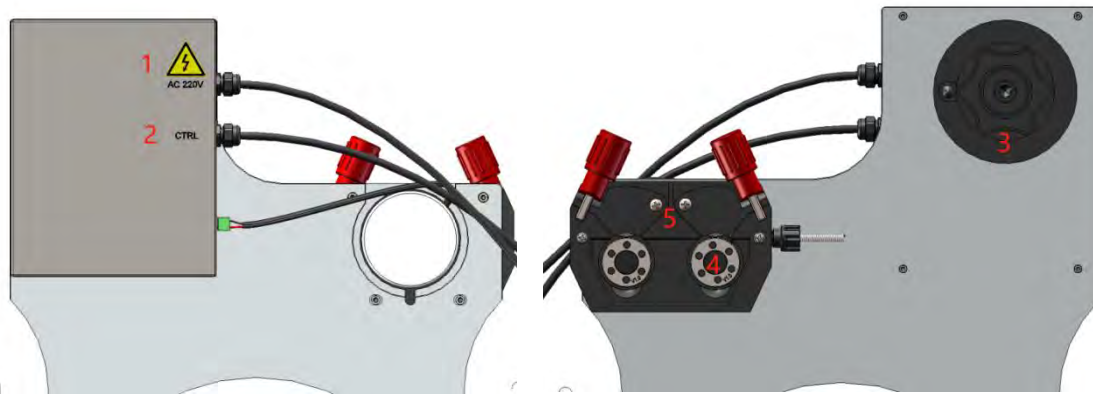

Figure 3.6

No.	Name	DESCRIPTION
1	AC220V	Connect to 220V AC OUTPUT on the rear panel
2	CTRL	Connect to CTRL-INTERFACE on the rear panel
3	damping shaft	Used to placing wire spools
4	wire feed wheel	Used to fix the welding wire
5	Wire feed device	Used to control the pumping of welding wire

Chapter 4 Preparation before use

4.1 Precautions

(1) The Laser Welder needs to be placed horizontally and fixed as necessary. It must not be inverted, sideways, vibrated or impacted.

(2) When connecting the power cord and control line, be sure to ensure that the power supply is disconnected. Live operation.

(3) When the Laser Welder is connected to the gas line, it is necessary to recognize the air inlet and outlet signs and connect according to the signs.

(4) During the disassembly and assembly of the armored pipe, it is necessary to avoid stepping on, excessive bending, and heavy objects crushing the armored pipe. , if the armored pipe is structurally damaged due to external force, which in turn causes damage to the Laser Welder, the warranty will be void.

	<p>CAUTION : Please keep the protective cap of the welding gun properly to prevent it from being contaminated; otherwise, it will cause indirect pollution to the welding gun when the protective cap is put on.</p>
---	---

	<p>CAUTION : All control lines should be powered off before being connected, reviewed, modified, etc. Operation with power on may cause damage to the machine.</p>
---	---

(5) During the installation and disassembly process, please be careful to handle the welding gun gently and avoid vibration.

(6) The minimum bending radius of the output optical cable of the Laser Welder shall not be less than 20cm during non-working conditions such as transportation and storage; In the light-emitting state, the minimum bending radius shall not be less than 30cm.

	<p>CAUTION : The laser output optical cable must be placed in a natural state as much as possible, and twisting of the output optical cable is prohibited; The coiling diameter of the output optical cable is too small, which may cause damage to the machine.</p>
---	---

4.2 Wire connection

4.2.1 Wire feeder wire connection

The specific operations are as follows:

1、 Remove the protective cover of CTRL-INTERFACE on the rear panel (as shown in Figure 4.1). After removal, as shown in Figure 4.2.

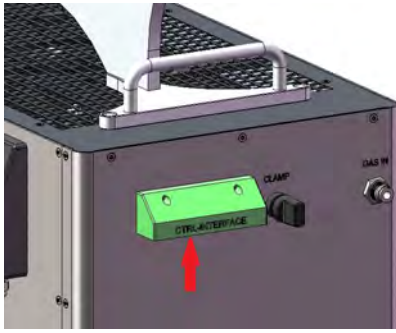

Figure 4.1



Figure 4.2

2、 Connect the wire of the CTRL (as shown in Figure 4.3) to the CTRL-INTERFACE. Connect it according to the mark on the wire. Fix it tightly, and then install the protective cover..



Figure 4.3

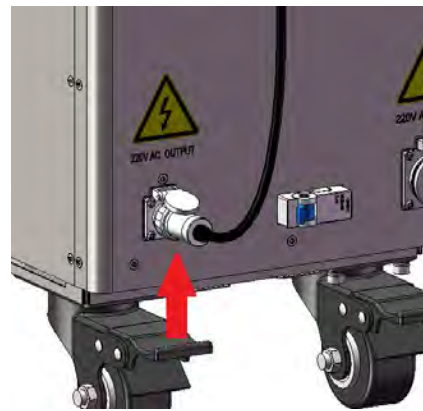

Figure 4.4

3、 Connect the wire corresponding to AC220V (as shown in Figure 4.3) to the 220VAC OUTPUT (as shown in Figure 4.4). The wire must be firmly fixed..

4.2.2 External circuit connections

Please refer to the relevant power requirements in Table 2.2. Before connecting the power supply, please ensure that the input voltage specification meets the standards stated in it.

The accessories include the power cord as shown in Figure 4.5. Connect it safely to the 220VAC external circuit. After turning off the external circuit, insert the connector of the cable into the 220VAC INPUT (Figure 4.6) . Do not operate with power on , please make sure the ground wire is grounded.



Figure 4.5



Figure 4.6

	<p>Warning: This product is powered by 220V AC. Disconnecting the product grounding will cause the product shell to be charged, which may cause personal injury to the operator. Do not plug or unplug the wire plug while the power is on. It is easy to cause electric shock and personal injury. Electrical parts are damaged, such damage is not covered by the warranty.</p>
---	--

4.3 GAS connection

This laser welder must be connected to a sufficient amount of auxiliary gas before it can operate, so as to dissipate the heat load generated during operation and protect the welding joint from damage caused by splash generated during the work.

Commonly used gases are inert gases such as Argon and Helium. The purity of the protective gas must meet 99.99%. In order to ensure the welding effect, a pressure reducing valve with a flow meter (nominal flow rate 25L/min) needs to be used to accurately control the size of the gas flow. The gas needs to be adjusted during welding. Flow to 15-20L/min.

The gas line interface (GAS IN) is located on the rear panel, as shown in the figure below. A 6x4 PU pipe can be used (note: the gas pressure should not be greater than 0.7Mpa to avoid damage to the equipment).

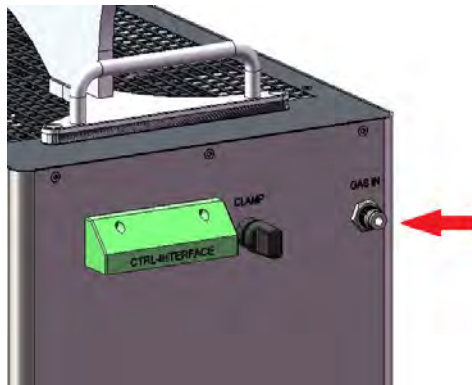



Figure 4.7 Location of GAS IN

	<p>CAUTION : Clean the filter regularly(See 7.3 for cleaning methods). Equipment damage caused by improper use/maintenance will not be covered by the warranty.</p>
---	--

The location of the filter is shown in the picture below.

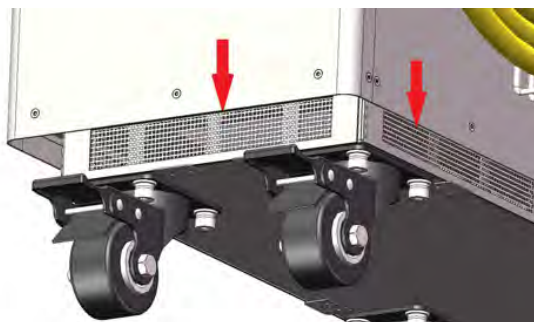

Figure 4.8 Illustration of filter position

4.4 Installation of clamp

Connect the round terminal on one end of the clamp to the CLAMP on the rear panel, and the other end is clamped to the welding workpiece..

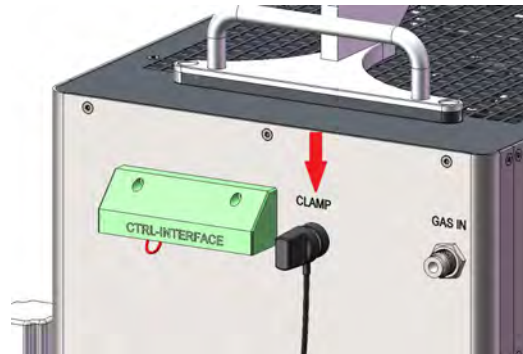

Figure 4.9

4.5 Installation of welding wire

Take out the corresponding accessories from the packaging accessories and install them on the welding gun and wire feeder in sequence, as shown in Figure 4.10.

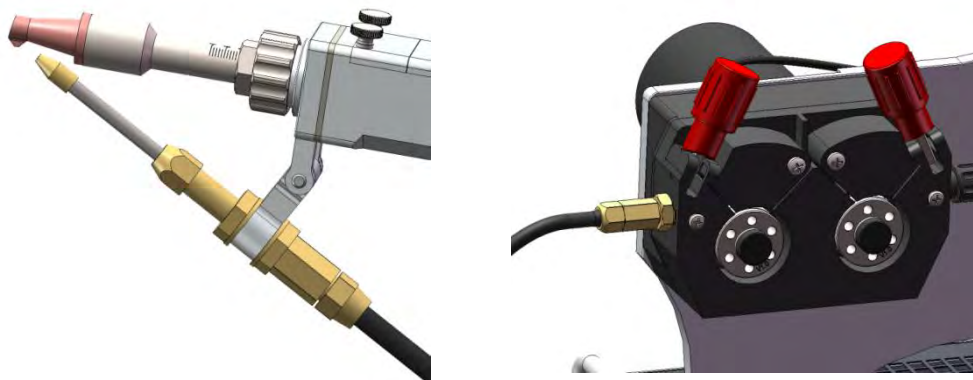

Figure 4.10

Install the welding wire spool and thread the welding wire. The process is as follows:

1. installing the welding wire spool.

A120/A150/A200: The max. diameter of the welding wire spool can be installed is 300mm, the thickness is 100mm, and the weight is no more than 15Kg.

A80: The max. diameter of the welding wire spool can be installed is 200mm, the thickness is 60mm, and the weight is no more than 5Kg.

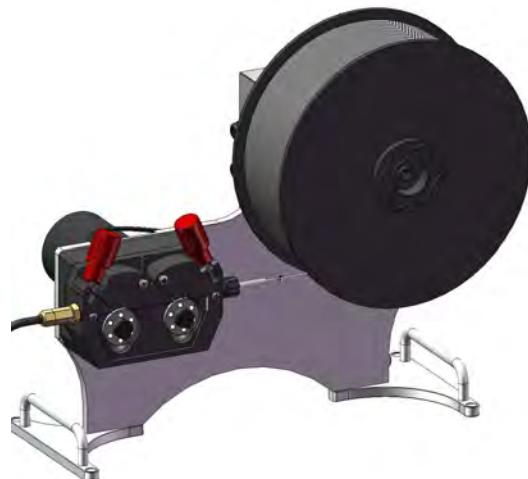

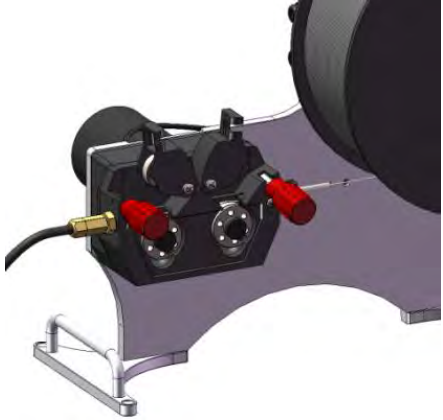
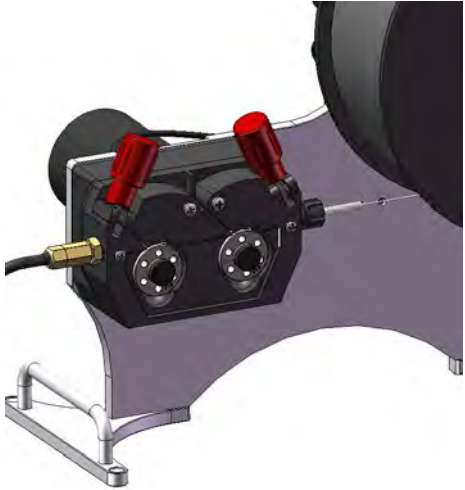
<p>2. threading the welding wire</p> <p>Pay attention to choosing the appropriate wire feed wheel.</p>	
<p>3. Tighten the welding wire</p> <p>Pay attention to moderate pressure.</p>	

The bushing shown in the figure below is used to fix relatively thin wire spools.

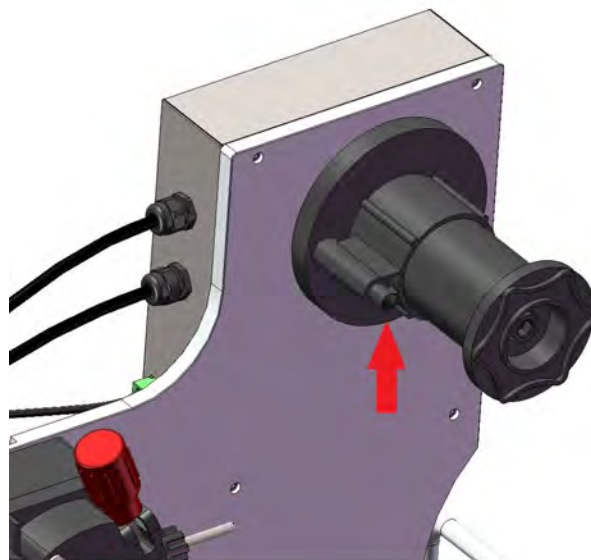

Figure 4.11

Chapter 5 Use of laser welder

5.1 Power on check

As shown in Figure 5.1, flip the air switch and power on the Laser Welder. At this time, the fan starts to rotate at a low speed, the touch screen lights up, and the welding gun has a red light output.

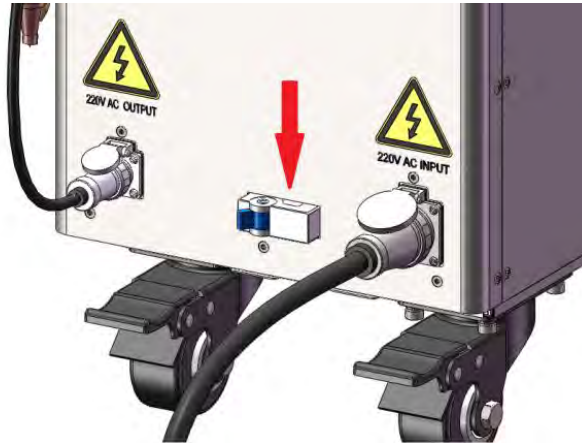

Figure 5.1 Air switch position

The parameters of the laser welder must be set by the touch screen. The touch screen can not only set parameters, but also store and call parameters, query equipment information and query faults. Let's introduce the main interface of the touch screen.

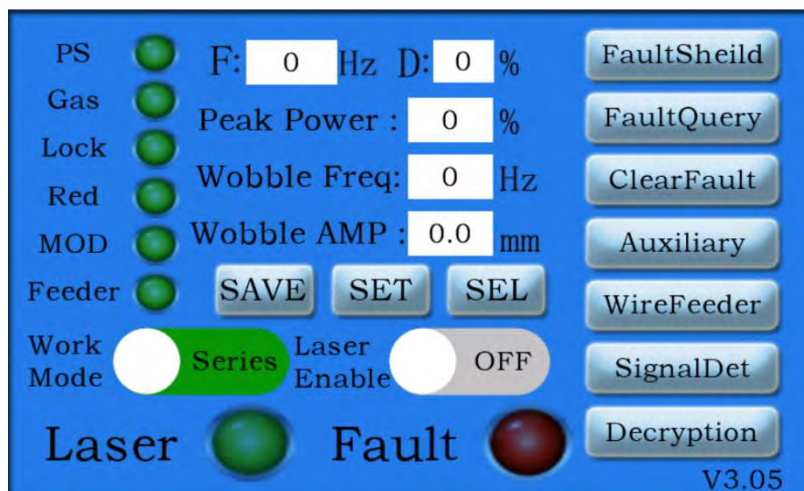

Figure 5.2 Main interface of touch screen

As shown in the figure, the left side is the status display, the middle part is the common parameter setting area(There are two work modes: Series and Spot, which can be switched by clicking the button), the right side is the other parameter setting and query setting area, and the lower right corner is the software version number.

The position of the red light needs to be checked. Only when the red light is emitted from the middle of the copper mouth can the next step be performed.

(1) There is no red light or the position of the red light has a large deviation and cannot be emitted normally from the copper nozzle. You need to contact after-sales personnel.

(2) The left and right offset of the red light position is relatively small and can be adjusted through the touch screen. Enter the auxiliary parameter interface from the main interface and modify the corresponding parameters from the galvanometer parameter correction section ,until the red light emits from the middle of the copper mouth, as shown in Figure 5.3.

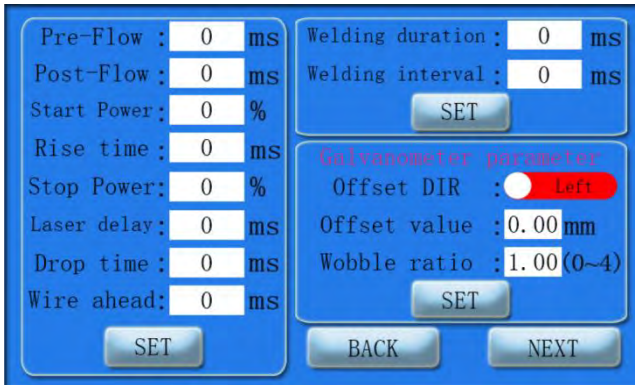

Figure 5.3 Auxiliary Interface

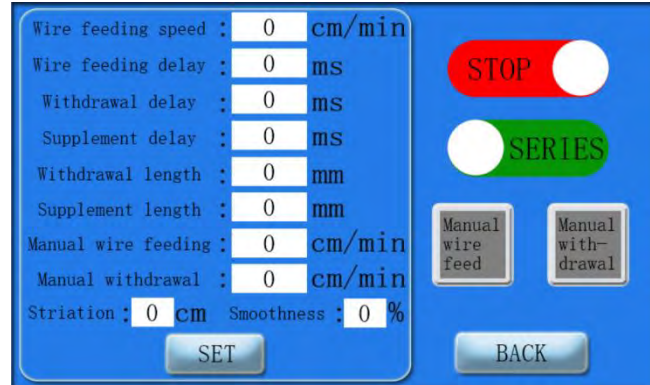

Figure 5.4 WireFeeder Interface



CAUTION :

If you do not check before lighting, the damage to the equipment will not be covered by the warranty.

5.2 Use of the Laser welder

The operation is as follows:

- (1) Connect to designated power source.
- (2) Connect to the specified gas.
- (3) Turn the air switch to power on the laser welder.
- (4) Check red light and protective window mirror.
- (5) Click the Peak power, Wobble Freq and Wobble AMP on the main interface in sequence to set the appropriate parameters (As shown in Figure 5.2).
- (6) Click on the Auxiliary and WireFeeder on the touch screen in turn, set the appropriate parameters, and click Set to confirm (As shown in Figure 5.3 and Figure 5.4).
- (7) Select the working mode. There are two working modes, continuous and spot welding mode.
- (8) Click Set and it will prompt that the setting is successful.
- (9) Clamp the clamp on the workpiece, touch the welding gun to the workpiece, and check the red light again. The red light is displayed in the center of the copper nozzle.
- (10) Click the laser switch button on the touch screen.
- (11) Press the welding gun switch, the laser will shoot out and start welding.

5.3 The setting of fish-scale welding

The operation steps are as follows (parameters are for reference only)

(1) As shown in Figure 5.2, the working mode of the main interface is set to spot welding.

(2) Set the spot welding parameters in the auxiliary parameter interface (Figure 5.3), set the spot welding duration to 150ms, and the spot welding interval to 40ms.

Set the automatic wire feeding speed on the wire feeding parameter interface to 30-60cm/min for better results.

5.4 Fault Shielding

Click the Fault Shield on the main interface to enter the fault shielding interface. There is a language switch button on it, as shown below.



Figure 5.5 Fault Shield Interface

It is not recommended to use the fault shielding function. If a fault is found, please contact after-sales service in time.

5.5 Fault Query

The fault button on the main interface lights up, indicating that the device has a fault and cannot operate. Click the Fault Query on the main interface, enter the fault query interface. You can query the fault type and time, as shown in the figure below.



No	Failure time	Type	Information

Figure 5.6 Fault Query Interface

If the laser welder fails, you should contact the after-sales personnel in time to handle it as soon as possible.

5.6 Signal Dect

Click Signal Dect on the main interface to see some status parameters of the Laser Welder, as shown below.

I1 : 0.0 A	T1 : 0.0 °C	PD1 : 0 mV
I2 : 0.0 A	T2 : 0.0 °C	PD2 : 0 mV
U1 : 0.0 V	T3 : 0.0 °C	PD3 : 0 mV
U2 : 0.0 V	T4 : 0.0 °C	PD4 : 0 mV
Set Power : 0 %	Red Current : 0 mA	
Working hours : 0		

Figure 5.7 Signal Dect

5.7 Decryption

Click the Decryption on the main screen to decrypt the device, as shown below.

Firmware Ver : 0.00 Product No :

Class A Permanent

NO Permanent

Figure 5.8 Decryption

Chapter 6 Process selection

6.1 Focus

1. The laser focus is the laser focus position after focusing the parallel light after beam expansion through the focusing lens, and the thinnest part of the cone-shaped shape is the laser focus position

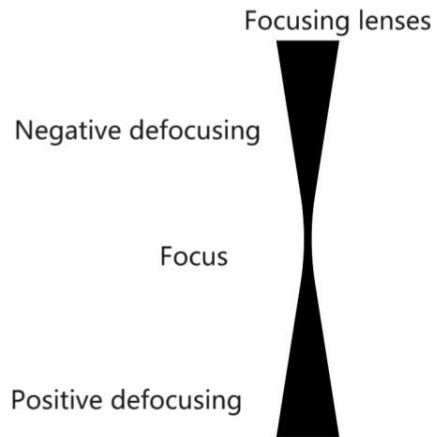

Figure 6.1

2. Defocusing refers to the distance of the workpiece surface away from the focal plane, and the defocusing method is divided into two types: positive defocusing and negative defocusing

3. If the focal plane is above the workpiece, it is positive defocusing, and vice versa, it is negative defocusing. When the amount of positive and negative defocus is equal, the power densities of the corresponding planes are approximately the same, but in practice the shape of the melt pool obtained is different. In the case of negative defocusing, a greater melt depth is obtained, which is related to the formation process of the melt pool. Experiments have shown that the material starts to melt when heated by the laser for 50-200ms, forming a liquid-phase metal that partially vaporizes to form a high-pressure vapor, which is ejected at a very high velocity and emits a brilliant white light. At the same time, the high concentration of gas moves the liquid metal to the edge of the melt pool, forming a depression in the center of the pool. Negative defocusing, the internal power density of the material is higher than the surface, easy to form a stronger melting, gasification, so that the light energy to the deeper material transfer. Therefore, in practice, when the melting depth is large, negative defocus should be used, and positive defocus should be used for welding thin materials;

4. Focus position: spot minimum, energy maximum point; spot welding can be used, or small energy and require a small point;

5. Negative defocus position: the spot is slightly larger, the farther away from the focal point of the spot is larger, suitable for deep melt continuous welding and deep melt spot welding;

6. Positive defocus position: the spot is slightly larger, the farther away from the focal point of the spot is larger, suitable for the continuous welding of the surface sealing welding or melting depth requirements are not high occasions.

6.2 Shielding gas selection

Auxiliary air blowing is an essential process in high-power laser welding. On the one hand, it is to prevent metal materials from sputtering and contaminating the focusing mirror (coaxial protective gas); on the other hand, it is to prevent high-temperature plasma generated during the welding process. Excessive accumulation of particles blocks the laser from reaching the surface of the material; the third aspect is to blow protective gas to isolate the air to protect the welding pool from oxidation. The type of auxiliary gas and the amount of blowing air have a great impact on the welding results. Different The blowing method will also have a certain impact on the welding quality.

Commonly used protective gases are nitrogen or argon.:

(1) It is recommended to use nitrogen for stainless steel, carbon steel, galvanized sheets, and cold-rolled sheets for better welding effects.

(2) It is recommended to use argon gas for aluminum, copper, and titanium alloys for better welding effects. For titanium alloys, argon gas can effectively reduce cracks caused by the embrittlement of the weld after welding.

The gas flow rate should be guaranteed to be 14~20L/min, and the input pressure should not be greater than 0.7Mpa.

Note: Do not use mixed gas/nitrogen dioxide gas/oxygen.

6.3 Welding wire selection

According to the different welding plates, we choose different welding wires (gas shielded solid core welding wire)

1、Stainless steel material: stainless steel welding wire (ER304);

2、Carbon steel, galvanized sheet, cold rolled sheet Material: iron wire;

3、Aluminum material: Choose the corresponding welding wire according to the aluminum coefficient, generally choose 5 series aluminum welding wire (the material is hard and not easy to get stuck);

4、Copper material: Select the corresponding copper welding wire according to the copper material.

6.4 Selection of wire feed roller

The wire feed rollers are divided into V-type and U-type, equipped with 2 wire feed rollers each of 0.8/1.0 and 1.2/1.6.

The V-shaped wire feed wheel is suitable for welding wires with relatively high hardness such as stainless steel and carbon steel.

shaped wire feed wheel is suitable for relatively soft welding wires such as aluminum.

Please select the wire feed wheel according to your needs. If you need wire feed wheels of other sizes (1.6/2.0 and 2.0/2.5), you can contact our sales staff.

6.5 Use of copper nozzle

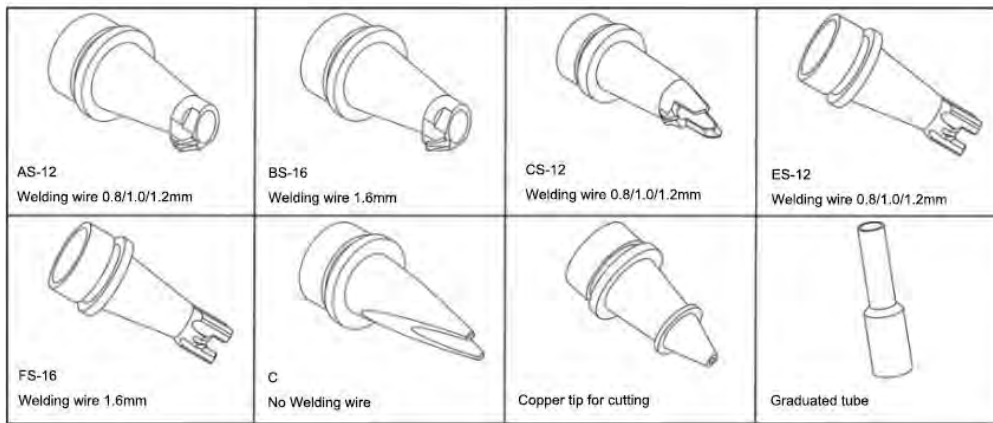

Figure 6.2

Suitable for tailor welding: AS-12, BS-16, CS-12, ES-12, FS-16, C

Suitable for external fillet welding: AS-12, BS-16, CS-12, ES-12, FS-16

Suitable for internal fillet welding: AS-12, BS-16, CS-12, C

Suitable for lap welding : AS-12, BS-16, CS-12, C

Suitable for edge welds : AS-12, BS-16, CS-12, ES-12, FS-16

Suitable for cutting: Copper tip for cutting

6.6 Process parameter reference

The welding rules are as follows (reference):

1. The thinner the plate, the smaller the spot during welding, the thinner the welding wire used, the faster the wire feeding speed, and the faster the welding speed. The opposite is true for thicker plates.
2. Determine the size of the welding wire according to the thickness of the plate. The actual welding wire should not be larger than the thickness of the plate.
3. The lower the power during welding, the whiter the weld. As the power increases, the weld changes from color to black.
4. When galvanized sheets are welded with focus, the spatter is very large. Positive defocus welding is generally used to reduce the impact of spatter. If wire is required, please use iron wire for welding.
5. When welding aluminum plates, you need to find the laser focus again (aluminum is a highly reflective material, and the focus is different from stainless steel, carbon steel, etc.).

The following welding data comes from the A150 Laser Welder and is for reference only:

Table 6.1 A150 plate tailor welding data (wire feeding)

Material	Thickness (mm)	Swing amplitude (mm)	Swing frequency (Hz)	Power (%)	Welding wire (mm)	Wire feed speed (cm/min)	Gas flow volume (L/min)	Form
Carbon Steel	1	2-3	80	26-30	1.0	50-60	14-20	Through
	1.5	2-3	80	45-55	1.0	50-60	14-20	
	2	2-3	60	55-70	1.0	50-60	14-20	
	2.5	2-3	80	70-80	1.0	50-60	14-20	
	3	2-3	100	70-80	1.0	50-60	14-20	
	4	2-3	100	95-100	1.0	45-55	14-20	
	5	2	100	100	1.0	40	14-20	
Galvanized Sheet	2	2-4	50-60	60-75	1.0	70	14-20	Through
		2	55	50	1.0	50	14-20	White
	3	2-4	40	70-90	1.0	70	14-20	Through
		2-3	45	60	1.0	45	14-20	White
	4	2-3	25	95-100	1.0	40	14-20	Through
		2-3	50	55	1.0	65	14-20	White
Stainless Steel	1	2-3	50	35	1.0	80	14-20	Through
	1.5	2-3	50	30	1.0	80	14-20	White
	2	2-3	40-50	55-60	1.0	75	14-20	Through
		2-3	60-100	30-40	1.0	80-100	14-20	White
	2.5	2-3	50-60	31-45	1.0	50	14-20	Through
		2-3	50-80	30-45	1.0	80-90	14-20	White
	3	2-3	40-50	50-80	1.0	70	14-20	Through
		2-3	60-100	60-70	1.0	80-100	14-20	White
	4	2-4	20-50	90-100	1.0	30	14-20	Through
		2-4	40-60	60-90	1.0	40-60	14-20	White
Al	1	2	80	35-40	1.0	80	14-20	Through
	2	2-3	80	75-80	1.0	90	14-20	Through
	3	2-3	45	85-90	1.0	90	14-20	Through
	4	2	80	70	1.0	86	14-20	Smooth
Cu	1	2-3	80	30-45	1.0	30	14-20	Through
	2	2-3	80	45-55	1.0	35	14-20	
	3	2-3	60-100	55-70	1.0	35	14-20	
	4	2-3	100	80-90	1	35	14-20	

Table 6.2 Tailor welding data of A150 plate (without wire feeding)

Material	Thickness (mm)	Swing amplitude (mm)	Swing frequency (Hz)	Power (%)	Form
Carbon Steel	1	2-3	80	15-20	Through
	1.5	2-3	80	30-50	
	2	2-3	80	60-75	
	2.5	2.5	80	80	
	3	2.5	80	80	
	4	2.5	80	85	
	5	2.5	100	100	
Galvanized Sheet	2	2	45	50	Through
	3	2	25	95	
	4	2	25	100	
Stainless Steel	1	2-3	50	50	Through
	1.5	2-3	50	50-55	
	2	2-3	40-50	65	
	2.5	2-3	40-50	50-60	
	3	2-3	30-40	85	
	4	2	30	100	
Al	1	2	40-50	30-35	Through
	2	2.0	60	60	
	3	2.0	70-75	75-85	
	4	2.0	70-80	85-90	
Cu	1	2.5	100	30-35	Through
	2	2.5	100	40-45	
	3	2.5	100	50-55	

Chapter 7 Cleaning and Replacing of lens

7.1 Cleaning and replacing window mirrors

This product uses a protective window mirror with a diameter of 18mm and a thickness of 2mm. If the window mirror is stained, it must be cleaned and replaced in time, otherwise it will cause damage to the welding gun and even the laser welder.

The specific cleaning operations are as follows:

- (1) In a dust-free environment, wear finger cots, remove the window mirror holder, and seal the welding gun with masking tape to prevent dust from entering.
- (2) Lay the window mirror holder flat, rotate the ring and take it away to expose the window mirror.
- (3) Take out the window mirror and wipe it with an optical cleaning cloth dipped in alcohol (purity greater than 99.5%). Replace it in time. Do not wipe it repeatedly.
- (4) Check the window mirror. If there is no dust, install it into the window mirror holder. Then press the pressing ring, rotate it to a certain angle and put it into the welding gun.

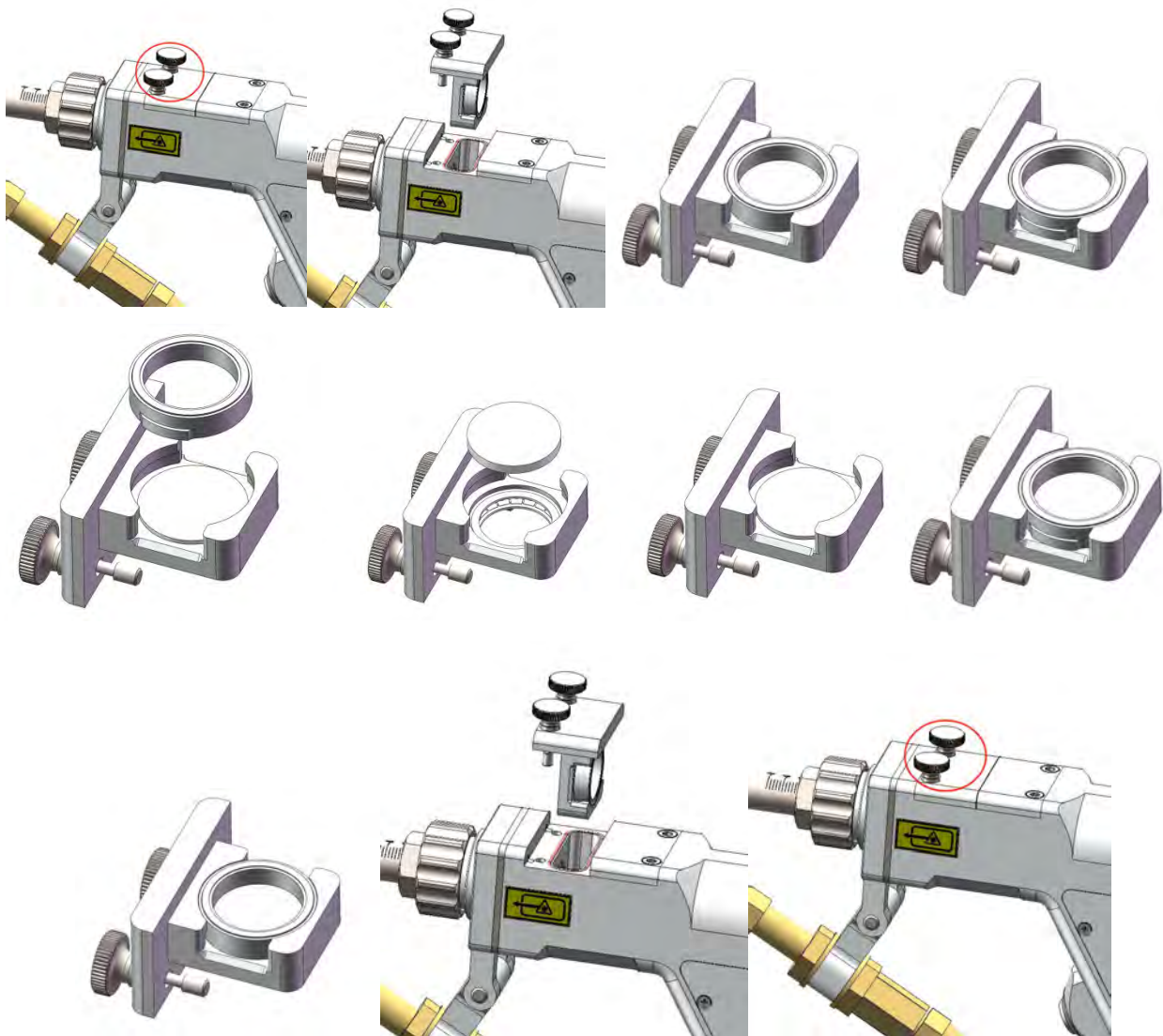

Figure 7.1

When the welding gun is not in use, the copper nozzle must be sealed to prevent contamination.

7.2 Cleaning and replacement of focusing lens

The specifications of the focusing lens are 20mm in diameter and 150mm in focal length. If you need to replace it, please contact our sales staff in time to purchase it.

The specific cleaning operations are as follows:

(1) In a dust-free environment, wear finger cots, remove the focusing lens holder, and seal the welding gun with masking tape to prevent dust from entering.

(2) Lay the focusing lens holder flat, rotate the pressing ring and take it away to expose the focusing lens.

(3) Take out the focusing lens and wipe it with an optical cleaning cloth dipped in alcohol (purity greater than 99.5%). Replace it in time. Do not wipe it repeatedly.

(4) Check the focusing lens. If there is no dust, install it into the focusing lens holder (with the flat surface facing down). Then press the pressing ring, rotate it to a certain angle and put it into the welding gun. Tighten the screws.

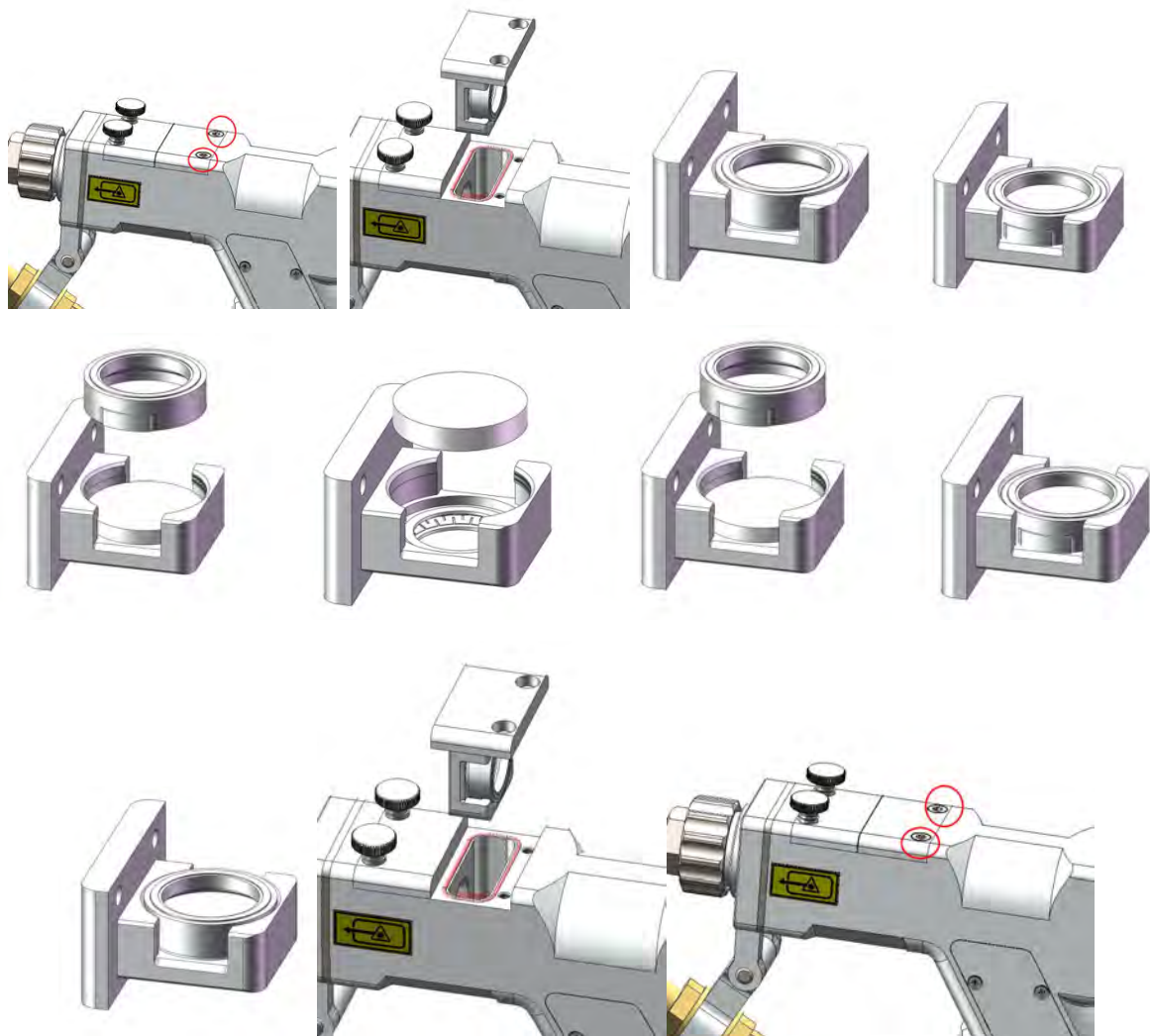

Figure 7.2

7.3 Cleaning of air ducts

This product uses air cooling. Blockage of the air duct will result in poor heat dissipation and serious damage to the equipment. Therefore, the air duct needs to be cleaned regularly according to the working conditions. First, the filter at the air inlet needs to be cleaned.

The position of the filter is as follows. The filter is fixed by magnetic suction. Be careful not to bend or damage it when disassembling and assembling.

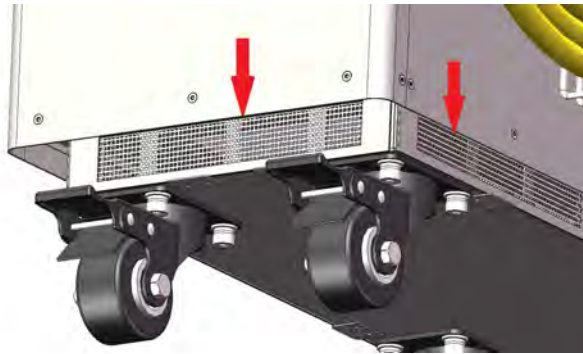

Figure 7.3 Illustration of the position of the filter (note that it is available in four directions)

The disassembly and assembly process of the filter is shown in the figure below (taking one side as an example)



Figure 7.4 Filter removal diagram

After removing the filter, use high-pressure gas to clean the internal air duct of the welding machine to remove debris on the air duct and filter, and then install the filter to the welding machine. Note that the filter must be installed in place to prevent it from falling off.

The installation steps are shown in the figure below:

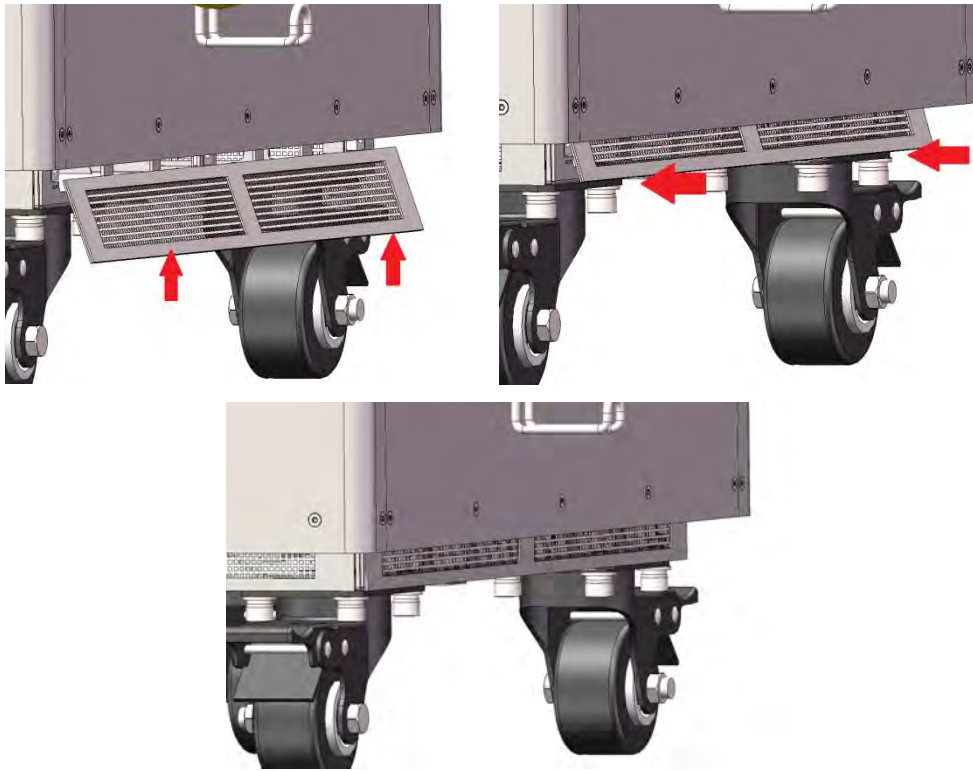

Figure 7.5 Filter installation diagram

Chapter 8 Common faults treatment

8.1 Fault alarm and query

In case of fault alarm, the laser will automatically turn off by turning off the internal power supply. At the same time, the fault signal in the 12-PIN CTRL-INTERFACE (ALARM_OUT+—pin 5, ALARM_OUT—pin 6) on the rear panel will be turned on, and the fault light will light up in the touch screen. If the customer needs to know the fault type, they can click “FaultQuery” to view. If the customer needs to know more details, they can click on the "Details" on the second page of the FaultQuery on the touch screen.

8.2 Troubleshooting solution

The failure instructions and possible solutions are as follows.

Table 8.1 The failure instructions and possible solutions

No.	MESSAGE	DESCRIPTION	SOLUTION
1	INTERLOCK Fault	Pin 3 and Pin 4 of CTRL-INTERFACE are not shorted.	Connect pin 3 and pin 4 to the safety door or short circuit directly. Then restart the laser. If there is still a fault after all of above treatments, please contact our after-sales service personnel.
2	INTEG1 Fault	RESEVED	RESEVED
3	INTEG2 Fault	Laser internal optical path detection failure	Contact our after-sales service personnel to see if you can continue to use the laser.
4	PrevBurn1 Fault	RESEVED	RESEVED
5	PrevBurn2 Fault	Laser internal optical path detection failure	Contact our after-sales service personnel to see if you can continue to use the laser.
6	IdleCur1 Fault	The current value when the laser is turned off exceeds the upper limit.	Restart the laser. If it happens frequently, please contact our after-sales service personnel.
7	IdleCur2 Fault	The current value when the laser is turned off exceeds the upper limit.	Restart the laser. If it happens frequently, please contact our after-sales service personnel.
8	CurHard1 Fault	The current value exceeds the hardware threshold.	Check if the 220V AC power supply of the laser is stable. If it is stable, reduce the peak output power of the laser. If the fault still occurs, please contact our after-sales service personnel.
9	CurHard2 Fault	The current value exceeds the hardware threshold.	Check if the 220V AC power supply of the laser is stable. If it is stable, reduce the peak output power of the laser. If the fault still occurs,

No.	MESSAGE	DESCRIPTION	SOLUTION
			please contact our after-sales service personnel.
10	Trial Expires Fault	Trial time limit exceeded.	Contact our after-sales service personnel to see if you can continue to use the laser.
11	Timing Chip Fault	The timekeeping chip faults.	Please contact our after-sales service personnel.
12	Over Power Fault	The power consumption of the driver board exceeds the maximum value.	Check if the 220V AC power supply of the laser is stable. If it is stable, but the fault still occurs, please contact our after-sales service personnel.
13	T1 Fault	The temperature at the pump source exceeds the upper temperature limit.	When confirming that the working environment of the laser is lower than the usage requirements, restart the laser. If the fault still occurs, please contact our after-sales service personnel.
14	T2 Fault	The temperature at the fiber exceeds the upper temperature limit	When confirming that the working environment of the laser is lower than the usage requirements, restart the laser. If the fault still occurs, please contact our after-sales service personnel.
15	T3 Fault	RESEVED	RESEVED
16	T4 Fault	RESEVED	RESEVED
17	No Gas Fault	The air pressure at the GAS IN is lower than the set value.	Ensure that the air pressure at the GAS IN is greater than 5L/min, restart the laser, If the fault still occurs, please contact our after-sales service personnel.
18	Power Supply Fault	The power supply is abnormal.	Check if the 220V AC power supply of the laser is stable. If it is stable, but the fault still occurs, please contact our after-sales service personnel.
19	Temp Chip 1~4 Fault	The chip of temperature measurement faults.	Please contact our after-sales service personnel.

In addition to the conditions in the table, if you have other questions or malfunctions, you can also contact Reci for help.

Chapter 9 Warranty and Return

9.1 General warranty

While all products manufactured according to the orders or specifications are delivered, the products with problems issued from materials and technologies shall be guaranteed by Recipro, as long as the laser is used in accordance with specifications.

When a problem is found, the customers should do as below:

- Contact with the after-sales service personnel of Recipro at the first time, then put forward the requirements in writing within a month (30 days) from finding the problems.
- In case of returning to the factory for maintenance, packaging and transportation shall be carried out in accordance with the requirements of this Guide.
- A third party will never covered by the warranty.

9.2 Limit of warranty

The following damages (including the overall damage of the machine, the damage of parts, optical fiber, etc.) are not covered by the warranty:

- Damages caused by tampering, opening, MIS installation, improvement intention, etc. without Recipro personnel.
- Damage caused by inappropriate operations and negligence.
- Damage caused by using beyond the limit of the product.
- Damage caused by a violation the information and warning in the user guide.



CAUTION:

The customer has the responsibility to understand and operate according to the operation instructions in the user's guide. The damage caused by the wrong operation is not covered by the warranty.

9.3 Transportation

- Before transportation, all machines to be repaired or replaced must be reliably packed with the original packaging boxes provided by Recipro, otherwise any damage caused thereby will not be repaired free of charge.
- Please carry out inspection and acceptance according to the list when prepare to repairing or returning. If the machine to be repaired or replaced does not return accompanied with all its wires, Recipro will not send the wires again.