

WATER CHILLER  
**CW-3000**  
USER MANUAL



## Safety Warning:



Do not leave your machine unattended.

Avoid using any water but distilled in your machine as it can damage it over time.



Always keep a fire extinguisher and first aid kit nearby.

Do not attempt to access any electrical areas while the machine is on. Unplug the machine and wait for an hour before accessing panels.

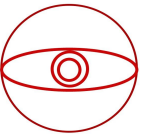

If your machines alarm is ringing, then don't start any projects until the issue has been resolved.

Inspect your machine before each use. Do not use if the machine or if the tubes are damaged in any way.



Always maintain a clean work area.

Looking for financing or eager to buy, contact Sales:



M-F 8AM-5PM PST  
[sales@fslaser.com](mailto:sales@fslaser.com)  
702-802-3101

Need help, visit us at our [Help Center](#) or contact Support:



M-F 8AM-5PM PST  
[support@fslaser.com](mailto:support@fslaser.com)  
702-802-3103

## Specifications:

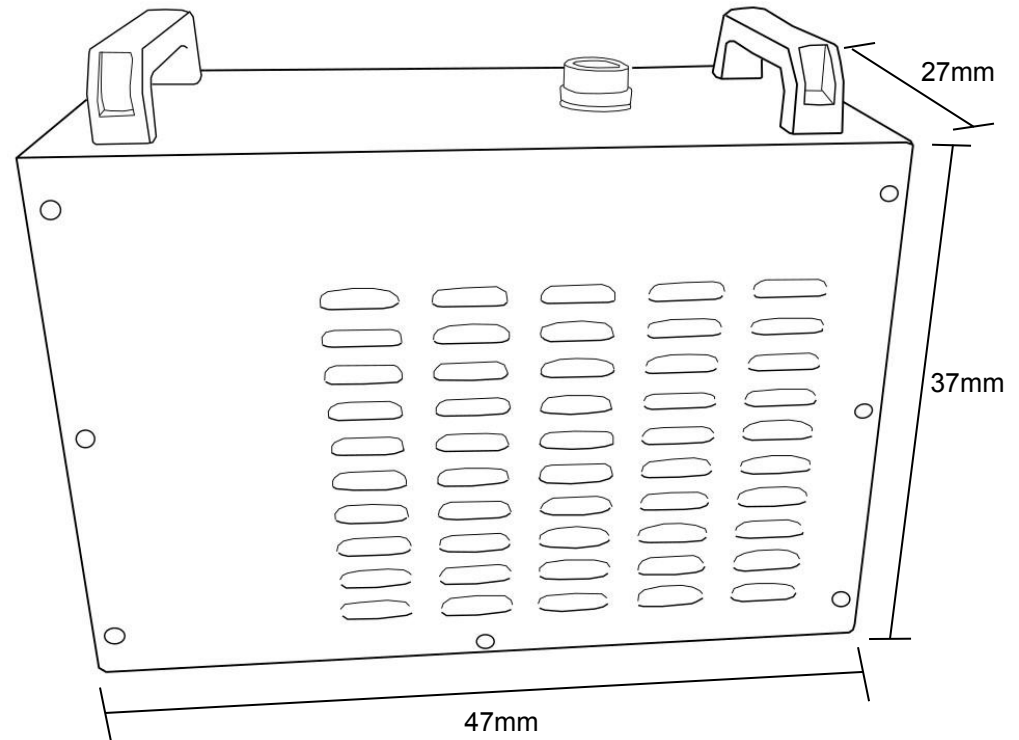

<b>Dimension:</b>	47mm X 37mm x 27mm
<b>Voltage:</b>	AC 100 - 120V
<b>Current:</b>	0.9 A
<b>Cooling:</b>	50W/°C
<b>Water Capacity:</b>	9 Liters

## Diagrams:

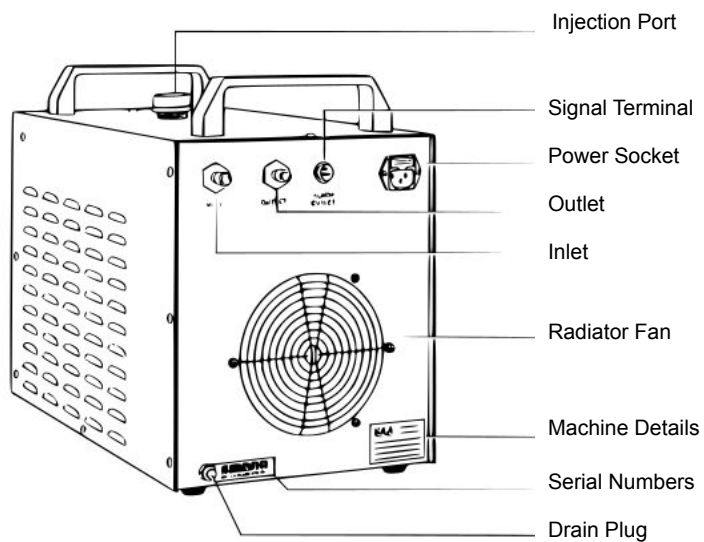
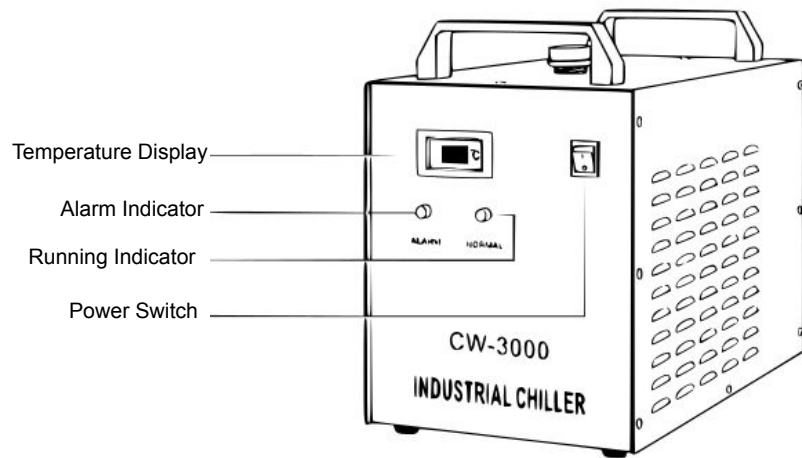

## Alarm Description:

The chart below can assist in becoming acquainted with the various alert indicators of the machine and the possible problems that may occur.

Red Indicator	Green Indicator	Buzzing	Out H1, H2	Out H1, H3	Condition
⊘	✓	⊘	⊘	✓	Normal
✓	⊘	✓	✓	⊘	Water Stopped
✓	⊘	✓	✓	⊘	Water Shortage
✓	⊘	✓	✓	⊘	Pump Issues
✓	⊘	✓	✓	⊘	Machine temperature exceeded 60°C
			✓	⊘	Faulty circuit
			✓	⊘	Power Outage

Note: The flow alarm is connected to an open and closed relay, therefore it required the operating current to be less than 5 A and the working voltage to be less than 300V.

## Troubleshooting:

The following chart lists some of the common issues experience with water chillers.

Issue	Cause	Potential Solution
Machine turns on but is not electrified	The machine is not getting proper electricity.	Check to make sure the power cord is plugged in properly. If that is the working then the fuse must be burnt out and needs to be replaced.
Water Tubes are properly connected but the red light is on and there's no water flow	There is not enough water inside the system.	Check water level. If the water is full, then check for leakage.
The water is flowing but the red light is on	There is not enough water inside the system.	Check the water tubes for leakage.
High temperature	The water chiller has reached a high temperature either by poor ventilation or due to excessive heat.	Replace the water will room temperature water. Make sure the chiller is placed in a well ventilated area to draw in air.
The fan is not turning on	Check the water temperature. If the temperature is below 20°C, then the fan will not turn on.	If the temperature is above 25°C, then contact support.
Alarm is still on after adding/replacing water	There is a possibility that water is inside the machine.	Check the water tubes for leakage. Make sure the injection cap and its surroundings are dry before covering the port.
Water is draining slow	There is no air to help with draining	Open the Injection port to let in air.

For issues not listed above, we recommend looking at our [Help Desk](#) for more information.